

# **MODEL M-1894**

**PROM PROGRAMMER**

**- OPERATION MANUAL**

## Preface

Thank you for purchasing Minato gang programmer Model-1894. Please read through this manual to best use of Model-1894. Please keep this manual in handy and refer it whenever needed.

Contents may be changed without a prior notice.  
Unapproved reproduction is prohibited.

The first edition February.2002  
The second edition August.2002  
The third edition October.2002

# TABLE OF CONTENTS

TABLE OF CONTENTS .....	i
-------------------------	---

## BEFORE USING THE PROGRAMMER

FOR SAFE OPERATION .....	2
HOW TO READ THIS MANUAL .....	5
ILLUSTRATIONS FOR THE OPERATION .....	6
OUTLINE OF THE PRODUCT .....	7
STANDARD ACCESSORIES .....	8
INSTALLATION AND TURNING ON THE POWER .....	9
SELF CHECK .....	9
NAME AND FUNCTION OF EACH KEY .....	11
SOCKET UNIT .....	14
INSERTING A DEVICE IN A SOCKET .....	18
HOW TO READ DISPLAY .....	19
KEY OPERATION ON INITIAL DISPLAY .....	20

## BASIC OPERATION

TO PROGRAM A DEVICE .....	22
SET A DEVICE CODE .....	23
AUTO SELECT .....	23
SETTING A DEVICE BY KEY OPERATION .....	25
COPY (Copying Device Data) .....	27
ERASE (Erase Data in a Device) .....	29
BLANK (To Check the Erase Status of the Device Data) .....	31
PROG (To Program Device Data) .....	33
VERIFY (To Verify the Device Data and the Buffer Memory) .....	35
CONT (Continuous Mode) .....	38
REMARKS .....	41
CONTACT CHECK .....	41
ID CHECK .....	42
DISPLAY OF OPERATING TIME .....	43
DISPLAY OF SUM AND XOR .....	43

## ADVANCE OPERATION MODE

ADVANCE OPERATION MODE .....	45
USING MENU .....	45
LIST OF MENU .....	46
PAE (Specify operating address of the device) .....	47
READVCC (Change device read voltage) .....	48
VERIFY PATTERN (Changing the number of verify) .....	49

ID CHECK (Setting of ID CHECK) .....	50
PROTECT MODE (Setting of device data protect mode) .....	51
PROTECT SETTING (To change protect setting for protected data) .....	54
REPEAT MODE (Setting of Repeat Mode) .....	55
SET PRG MODE (Programming different data on multiple device) .....	56

## MEMORY

LITTLE-ENDIAN MODE .....	61
BUFFER INIT (Initializing Buffer Memory Data) .....	62
BUFFER DUMP/EDIT (Dumping and editing buffer memory data) .....	63
BYTE SWAP (Buffer memory data byte swap) .....	64
WORD SWAP (Word swap of buffer memory data) .....	65
CHECK SUM (Calculation of add and sum) .....	66

## SYSTEM

DEVCHK/BUZZER/LED Setting Of Device-check, Buzzer, And LED .....	68
CHECKING THE FIRMWARE VERSION OF M1894 .....	69
UPDATING THE FIRMWARE VERSION OF M1894 .....	70

## DATA TRANSFER

DATA TRANSFER .....	72
RS CONFIG (Setting interface configuration) .....	73
DATA FORMAT (Setting transfer data format) .....	74
SERIAL IN (Data transfer: serial input) .....	75
SERIAL OUT (Data transfer: serial output) .....	76
PROTECT SR IN (Protected data transfer: serial input) .....	77
PROTECT SR OUT (Protected data transfer: serial output) .....	78
REMOTE CONTROL .....	79
IF SELECT (Selection of an Interface) .....	80
REMOTE CONFIG (Setting the condition of remote mode) .....	81
EXECUTING REMOTE MODE .....	83

## REMOTE COMMAND - COMMAND OPERATION -

CAUTION OF REMOTE OPERATION .....	85
HOW TO READ THIS CHAPTER .....	86
FORM OF REMOTE COMMAND .....	87
SIGNS TO BE USED IN REMOTE COMMAND .....	88
OUTPUT FORM OF THE RESULTS .....	89
LIST OF COMMANDS .....	90

EXPLANATION OF THE FUNCTION .....	91
CTRL+E CTRL+E (Execution of remote mode) .....	91
E, BY (end of remote mode) .....	91
RMD (Setting the condition of remote mode) .....	92
CTRL+D (Interruption of Operation) .....	93
H (Displaying list of help) .....	94
N, DV (Selection of device code) .....	95
OP, CP (Executing COPY) .....	96
Z, ER (Executing ERASE) .....	97
B, BL (Executing BLANK) .....	98
W, PG (Executing PROG) .....	99
V, VF (Executing VERIFY) .....	100
OT, CT (Executing CONT) .....	101
CK (Device contact check) .....	102
SIG (Setting of ID Check) .....	103
MD, PAE (Specifying device operating area) .....	104
S, DF (Setting data format for transfer) .....	105
BLK (Programming different data in multiple devices) .....	107
BS (Displaying buffer memory size) .....	109
REV (Displaying firmware version) .....	110
L, LS (Displaying buffer memory data) .....	111
BO, CS (Add 4 digits) .....	112
BO8, CS8 (Add 8 digits) .....	113
F, INI (Initializing buffer memory data) .....	114
SCH (Data search: match) .....	115
UNS (Data search: un match) .....	116
T (Move data) .....	117
P, PL, WD (Serial I/F data output) .....	118
RD (Serial I/F data input) .....	119
RL (Serial I/F data input) .....	120
PCH (Changing protect mote) .....	121
WP (Serial I/F protected data output) .....	122
RP (Serial I/F protect data input) .....	123

## MAINTENANCE

ERROR MESSAGE .....	125
ERROR MESSAGE DURING SELF TEST .....	125
ERROR MESSAGE DURING OPERATION .....	126
ERROR MESSAGE DURING REMOTE MODE .....	126
AFTER SERVICE .....	127
USER MAINTENANCE OF DEVICE PROGRAMMERS AND ADAPTERS .....	127



SPECIFICATION .....	128
SPECIFICATION OF M1894 .....	128
SPECIFICATION OF CONNECTOR (RS232C) .....	129
SPECIFICATION OF CONNECTOR (USB) .....	130
HEADQUATER .....	131



## BEFORE USING THE PROGRAMMER





Safety precaution .....	2
How to read this manual .....	5
Illustrations for the operation .....	6
Outline of the product .....	7
Standard accessories .....	8
Installation and turning on the power .....	9
Self check .....	9
Name and function of each key .....	11
Socket unit .....	14
Inserting a device in a socket .....	18
How to read display .....	19
Key operation on initial display .....	20

## SAFETY PRECAUTION





This operation manual describes the safety precautions of Model-1894 for our own safety. The following pictographs are used to prevent any injury of you and any damage on your property. When you operate Model-1894, please follow the safety instruction on this manual.

### Explanation of Pictographs

 <b>WARNING</b>	Indicates a potential hazardous situation in which the operator would be killed or seriously injured unless this precaution is observed.
 <b>CAUTION</b>	Indicates a potential situation in which the operator would be injured or property would be damaged unless this precaution is observed.







 Inhibit	This means "prohibited matters".
 Don't disassemble	This means "do not disassemble".
 Compulsion	This means " compulsory matters".
 Unplug Power Cord	This means " unplug the power cable".

# **WARNING**

 Compulsion	When operating this unit, be sure to follow warnings and cautionary instructions given by Minato Electronics Inc.
 Don't disassemble	Do not disassemble or modify this unit, A fire may start or you may get an electric shock.
 Unplug Power Cord	When finding a smoke, feeling an abnormal smell or hearing an abnormal sound, pull out the power plug immediately from the AC plug receptacle. If keep operating, a fire may start or you may get an electric shock owing to short-circuit. Consult with our authorized distributor.
 Unplug Power Cord	If dropped this unit or given a strong shock to the unit, pull out the power plug immediately from the AC plug receptacle. If keep operating, a fire may start or you may get an electric shock owing to short-circuit. Consult with our authorized distributor.
 Unplug Power Cord	If any liquid or foreign matter enters this unit, pull out the power plug immediately from the AC plug receptacle. If keep operating, a fire may start or you may get an electric shock owing to short-circuit. Consult with our authorized distributor.



## CAUTION

 Compulsion	<p>This unit shall be operated by an operator who has fully understood the operation manual of Model 1894</p> <p>Any liquid or condensation may damage this unit or the device.</p>
 Compulsion	<p>Before touching this unit, be sure to touch a near-by metal and remove electrostatic from your body so that this unit is not damaged by electrostatic. electrostatic may damage this unit and other devices.</p>
 Compulsion	<p>Do not use or leave the unit in humid or dusty area.</p> <p>It may cause an electric shock or damage the unit.</p>
 Compulsion	<p>Clean the unit surface, the device socket. Operation without removing dusts from them will probably result in a fire or a trouble. Try to clean them periodically.</p>
 Compulsion	<p>Do not cover the cooling fan and windows.</p> <p>It may cause a fire or damage the unit due to the accumulated heat on the unit. (Refer to Name and function of each key.)</p>
 Compulsion	<p>Do not step on the unit or put any heavy item on the unit.</p> <p>It may cause an injury or damage the unit.</p>
 Compulsion	<p>Do not perform ESD to the contact on the adapter's IC sockets due to its directly connecting the internal circuit.</p> <p>Also, do not get closer within 10mm from the contact for an ESD device which has more than 2kV.</p> <p>If the above case occurred for the ESD or getting closer within 10mm, it may cause wrong operation or any breakage.</p>

# How to read this manual

**Title** | **Overview about this page**

---

**PAE - Specify operating address of the device -**

M1894 is designed to access all address of the device. Also, you can specify the operating address of particular devices (PAE MODE-Program Address Entry)

The following three parameters can be set in PAE mode.  
 "Dev start": Operating start address (Device)  
 "Dev end" : Operating end address (Device)  
 "Buf start" : Operating start address (Buffer memory)

**Procedure to select the Menu**

MOD > [Device func.] > ENT  
 > [PAE mode.] > ENT

**Procedure to change settings**

[Left] [Right] : Change digit  
 [Up] [Down] : Change value  
 ENT : Move the cursor to "[ ]"  
 STAR : Enable changed value

PAE mode
Dev start = [0000000]
Dev end = 007FFFF
Buf start = 0000000

**Warning:** The unit of device address is the same as the data length of the device.  
 The unit of buffer address is fixed as one byte (8 bits). Please make a note of this especially for 16-bit device.  
 When device code is changed and power is turned on/off, it is changed to the default.

**Remarks:** The last two digits of address can not be changed on the device supporting page programming mode.  
 Some device prohibits to use a part of the address.  
 When address is changed, "P" for this mode is indicated on the display panel.  
 (Please refer to how to read the display )

47

Page number

















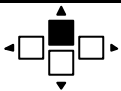

Warnings on operation are indicated. Please be sure to read.

Contents of the display

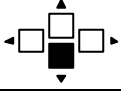
"Remarks"  
 Advices on operation are indicated.

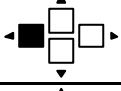
## Illustrations for the operation

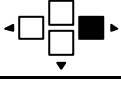
In this manual, the following illustrations are used to describe the operation of each key.

Illustrations for each operation	Corresponding key	Description
>		Go to the next step
	copy erase blank prog verify cont <input checked="" type="checkbox"/> <input type="checkbox"/> <input type="checkbox"/> <input type="checkbox"/> <input type="checkbox"/> <input type="checkbox"/>	Press COPY key
	copy erase blank prog verify cont <input type="checkbox"/> <input checked="" type="checkbox"/> <input type="checkbox"/> <input type="checkbox"/> <input type="checkbox"/> <input type="checkbox"/>	Press ERASE key
	copy erase blank prog verify cont <input type="checkbox"/> <input type="checkbox"/> <input checked="" type="checkbox"/> <input type="checkbox"/> <input type="checkbox"/> <input type="checkbox"/>	Press BLANK key
	copy erase blank prog verify cont <input type="checkbox"/> <input type="checkbox"/> <input type="checkbox"/> <input checked="" type="checkbox"/> <input type="checkbox"/> <input type="checkbox"/>	Press PROG key
	copy erase blank prog verify cont <input type="checkbox"/> <input type="checkbox"/> <input type="checkbox"/> <input type="checkbox"/> <input checked="" type="checkbox"/> <input type="checkbox"/>	Press VERIFY key
	copy erase blank prog verify cont <input type="checkbox"/> <input type="checkbox"/> <input type="checkbox"/> <input type="checkbox"/> <input type="checkbox"/> <input checked="" type="checkbox"/>	Press CONT key
	mod com <input checked="" type="checkbox"/> <input type="checkbox"/> <input type="checkbox"/> <input type="checkbox"/> dev ent	Press MODE key
	mod com <input type="checkbox"/> <input checked="" type="checkbox"/> <input type="checkbox"/> <input type="checkbox"/> dev ent	Press COM key
	mod com <input type="checkbox"/> <input type="checkbox"/> <input checked="" type="checkbox"/> <input type="checkbox"/> dev ent	Press DEV key
	mod com <input type="checkbox"/> <input type="checkbox"/> <input type="checkbox"/> <input checked="" type="checkbox"/> dev ent	Press ENT key
		Press UP key
		Press DOWN key
		Press LEFT key
		Press RIGHT key
	reset start <input type="checkbox"/> <input checked="" type="checkbox"/>	Press START key
	reset start <input checked="" type="checkbox"/> <input type="checkbox"/>	Press RESET key
I/O Command		At menu select, match the cursor “[ ]” to the corresponding title

## Outline of the product

Model-1894 (hereafter called M1894) is a gang programmer that supports various devices including high-density devices. It is equipped with 32 M bytes (256M bits) buffer memory. It can program 8 pieces of devices simultaneously.

Interface to PC is available for mass production at automated production lines. You can expect high performance in your production line.

In mass production line where QC is the bottom line, M1894 accomplishes various checking right away although you might not expect it due to its high operating speed. It also lowers the yield rate, which could be caused by initial failure of the devices.

### [Major features]

Unsurpassed operating speed (comparing to our former 8 gang programmer)

Standard 256M bits buffer memory (expandable up to 1-G bits)

Various devices are supported.

## Standard accessories

After unpacking, please check the following contents.

### BASIC SET

Main unit

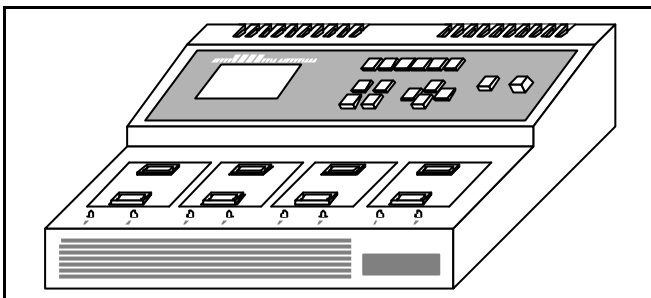

Power cable

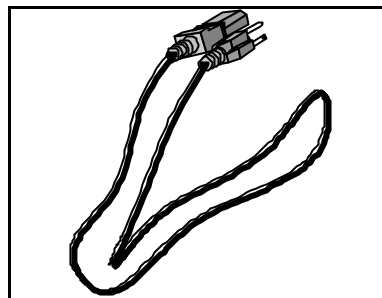

This operation manual  
Device list  
USB driver install disk

### OPTIONAL SET (The type and quantity is determined by your order.)

Socket unit

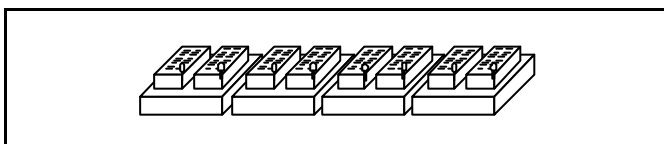

Conversion Adapter

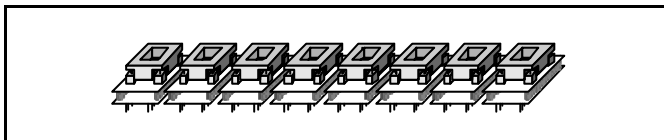

If any of them are missing or damaged, please contact to our local distributors.  
We recommend keeping the original packaging for a future tarns-shipment.

## Installation and turning on the power

Cautions on the installing environment and power switch are described.

### Caution for installing environment

1. Avoid to install near an equipment which generates high noise such as motor driven machine, electric soldering machine.
2. The unit must be leveled. Avoid vibration to the unit.
3. AC cable should be connected to designated power source.
4. Do not use multiple outlet extension plug
5. When plug in AC power cable, make sure that M1894 is switched off.

### Self check

1. When turning the power on, make sure that non-devices are set on the socket adapters. If power is turned on with devices left on the adapters, it may damage the devices.
2. After turning on the power, M1894 starts self (diagnosis) test. If the following display is appeared, the test is passed.

When ALL\_PASS is displayed, everything is fine.

```
M1894 Self check END
Self check ALL_PASS
Time <xx.xx.xx>
```

After a few seconds, the firmware version of the unit is displayed.

```
M1894 Ver1.00
AUG-2002
32M byte memory
```

Then self-test is completed and initial page is displayed. The last device before turning off the power is set on the programmer. Initial operation mode is "BLANK".

```
BLANK N 16bit x 1
AMD cd:020870
Am29DL32x_T
SU16-48D
```

\*When different socket unit is inserted, the default device of the base unit becomes valid.

When socket unit is not installed yet, the following message is displayed. The device code is not set yet. Install the socket unit on the programmer and set a device code.

```
BLANK      - - b i t x - -  
           c d : - - - - -
```

**Turning off the power**

When truing off the power, make sure that no device is set on an adapter. Socket unit(s) can be stayed on the programmer.

# Name and function of each key

(1) Display

(2) - (5) Setting keys

(6) - (11) Function keys

(12) - (13) Arrowkeys

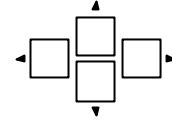
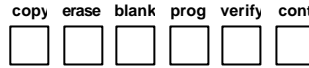
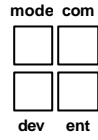

(2) MODE key  
 (3) COM key  
 (4) DEVICE key  
 (5) ENT key

(6) COPY key  
 (7) ERASE key  
 (8) BLANK key  
 (9) PROG key  
 (10) VERIFY key  
 (11) CONT key

(12) UP, DOWN  
 (13) LEFT, RIGHT

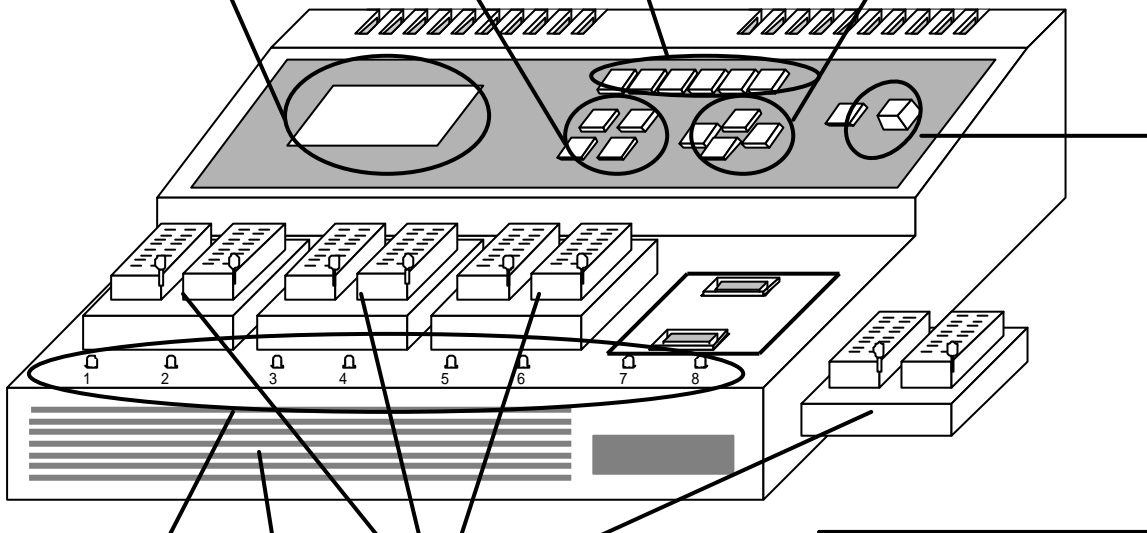

(17) PASS/FAIL LED

(16) SOCKET UNIT

(14), (15) RESET, START key

(18) Cooling window

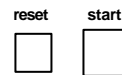

(14) RESET key  
 (15) START key

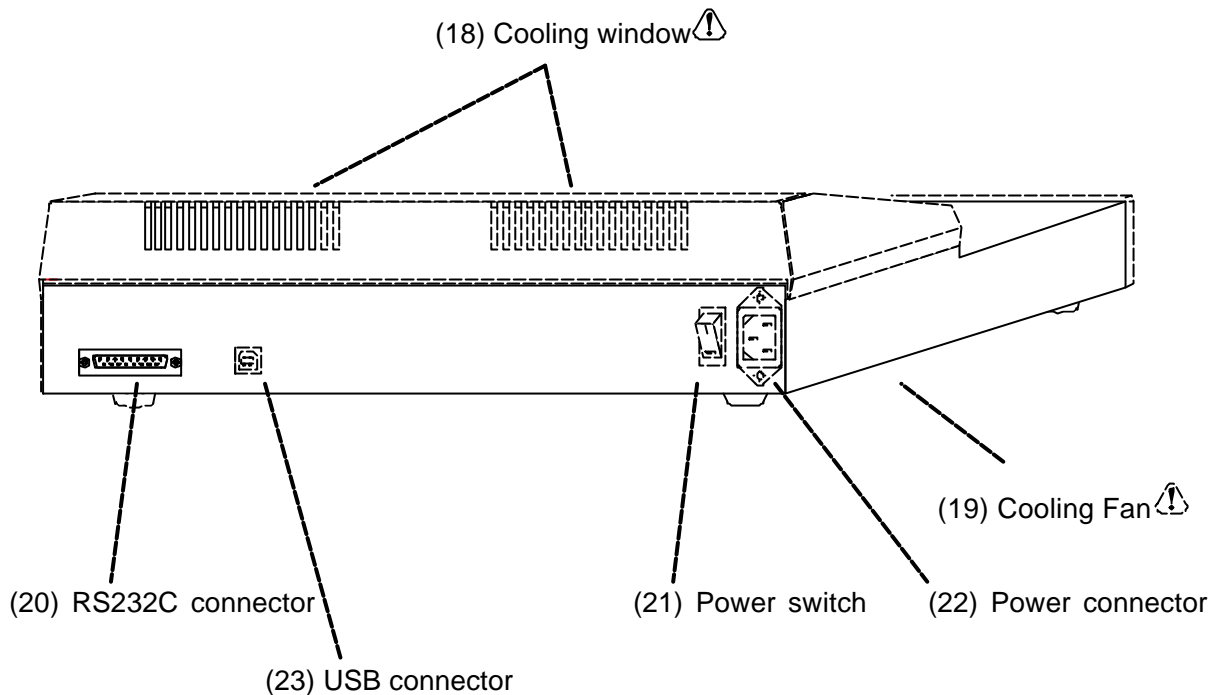

(1) LCD Display (20 x 4)

Selected device is displayed and all other functions are displayed.

(2) MODE key

It is used for editing memory data and communicating with PC.

(3) COM key

It is used for data check, edit mode change when editing memory data.

(4) DEVICE key

It is used to set a device.

(5) ENT key

It is used to select or enter the targeted function.

Function keys (6) – (11)

These keys are to execute basic function of the programmer. Basic functions consists of 6 types of function including "COPY","ERASE","BLANK","PROG(Program)","VERIFY","CONT". Each key has a designated function for easy of use.

By pressing only one of these keys does not execute the function. In order to execute the function, START key must be hit.

(6) COPY key



Copy data in the master ROM to the buffer memory of M1894

(7) ERASE key

Erase the data in the device

(8) BLANK key

To check if the data in the device is blank or not

- (9) PROG key  
To program data in the device
- (10) VERIFY key  
To compare the data between the device and the buffer of M1894
- (11) CONT (CONTINUOUS MODE) key  
To execute ERASE, BLANK, PROG, VERIFY sequentially
  
- (12) UP and DOWN arrow key  
To move cursor "[ ]" and to change the set value
- (13) LEFT and RIGHT arrow key  
To move cursor "[ ]" for each function and move to other digit
- (14) RESET key  
To cancel a function
- (15) START key  
To execute COPY, PROG and to fix a new setting
- (16) SOCKET UNIT  
According to the specification of the device, this unit converts the pin configuration.
- (17) PASS/FAIL LED  
To indicate the status of device. The result of programming is indicated in each socket in different color.
  
- (18) Cooling window   
Do not cover it. (Refer to Safety precaution.)
  
- (19) Cooling Fan   
Do not cover it. (Refer to Safety precaution.)
- (20) RS232C connector
- (21) Power switch
- (22) Power connector
- (23) USB connector  
When USB is used, USB drive must be installed on the PC. Please refer to the installation guide of USB driver.

## Socket unit

### Socket unit

In order to support various devices in minimum types of socket adapters, socket units are designed. While it is supporting fast changing device specification, this architecture to convert the pin configuration on the base unit makes our solution more affordable.

Minato named the base and pin converter as socket unit.

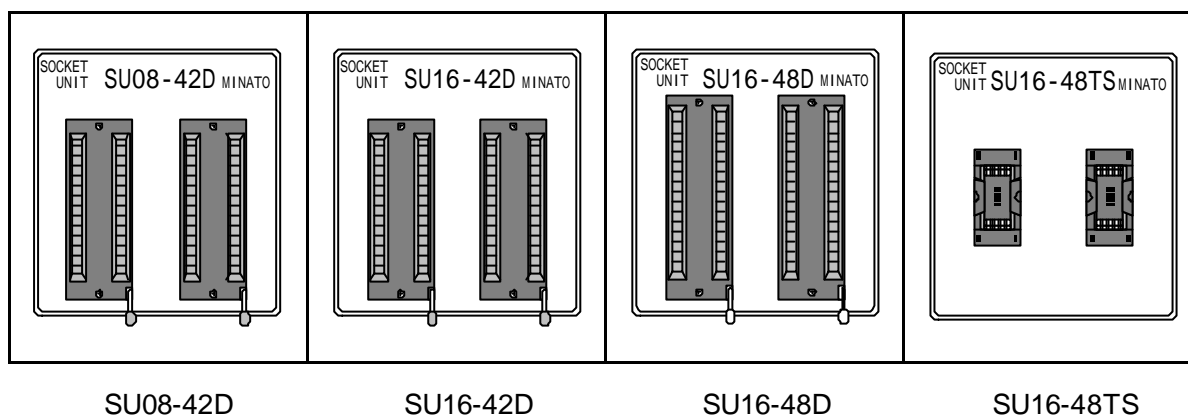

SU08-42D (Device-Socket: 42-pin DIP )  
For 8 bit device such as microcontroller

SU16-42D (Device-Socket: 42-pin DIP )  
For 16 bits device (EDEC type pin configuration)

SU16-48D (Device-Socket: 48-pin DIP )  
For 16 bits device (EIAJ type pin configuration)

SU16-48TS (Device-Socket: 48-pin TSOP Type-I )  
For 16bits device (EIAJ TSOP Type-I pin & package configuration)

### Numbering of the socket

It is number starting from left to right. Socket 1 is indicated as #1 or NO1 in this manual.

## Changing socket unit

Type of socket unit depends on the targeted device. Socket unit must be changed to the other type if other type of device is targeted. The socket unit can be changed when the power is on.

When you copy a master data, please insert it on LED number 1 and 2.

In the case of others, M1894 will operate if at least one unit is installed in any connector.

Coping a master data: (This chapter: Please refer to COPY)

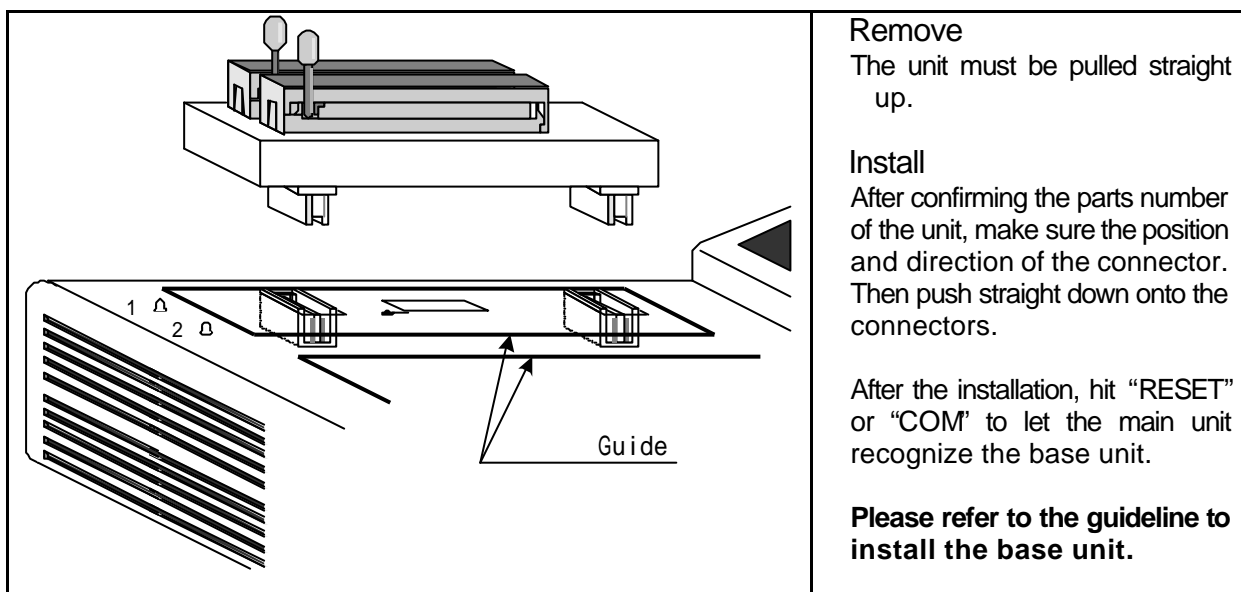

## Remarks

The base unit must be inserted firmly. Otherwise, error or irregular operation is occurred.

Do not slant it and insert. Do not apply too much pressure on the base unit. That may damage the connector.

Minimum quantity of the base unit to run the unit is one. When multiple number of the base unit is used, make sure that the same type is used. When different types are inserted and hit start, COPY, BLANK does not run and M1894 displays Socket Unit Error.

The same type of base unit can be installed in any slot. Please refer to separate device code list for the appropriate socket unit for each device.

The function of the key differs whether a socket unit is installed or not.

Status chart

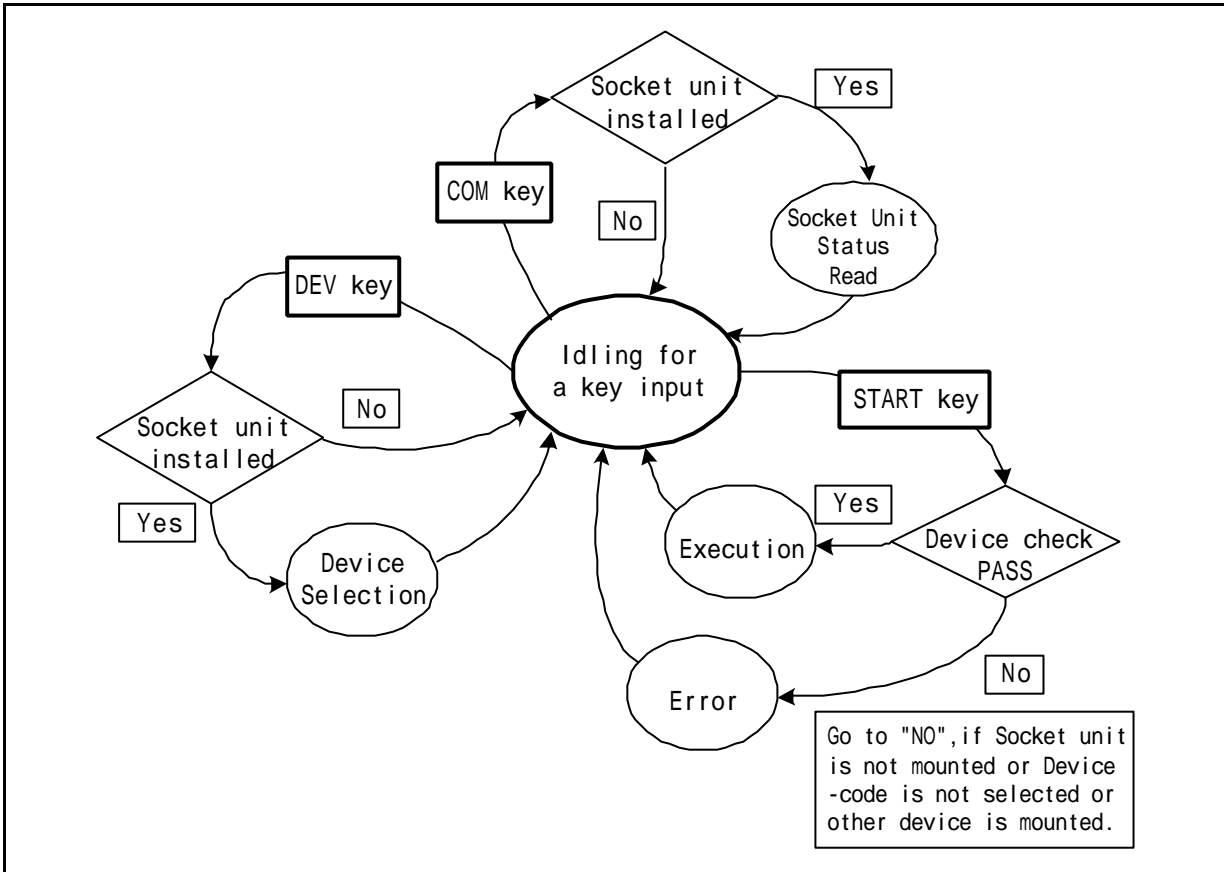

## Combination of device package and socket unit

Dip and TSOP (48-pin Type-I) device can be inserted directly in socket unit. For other package, a set of conversion adapters and socket unit are required according to the specification of the device.

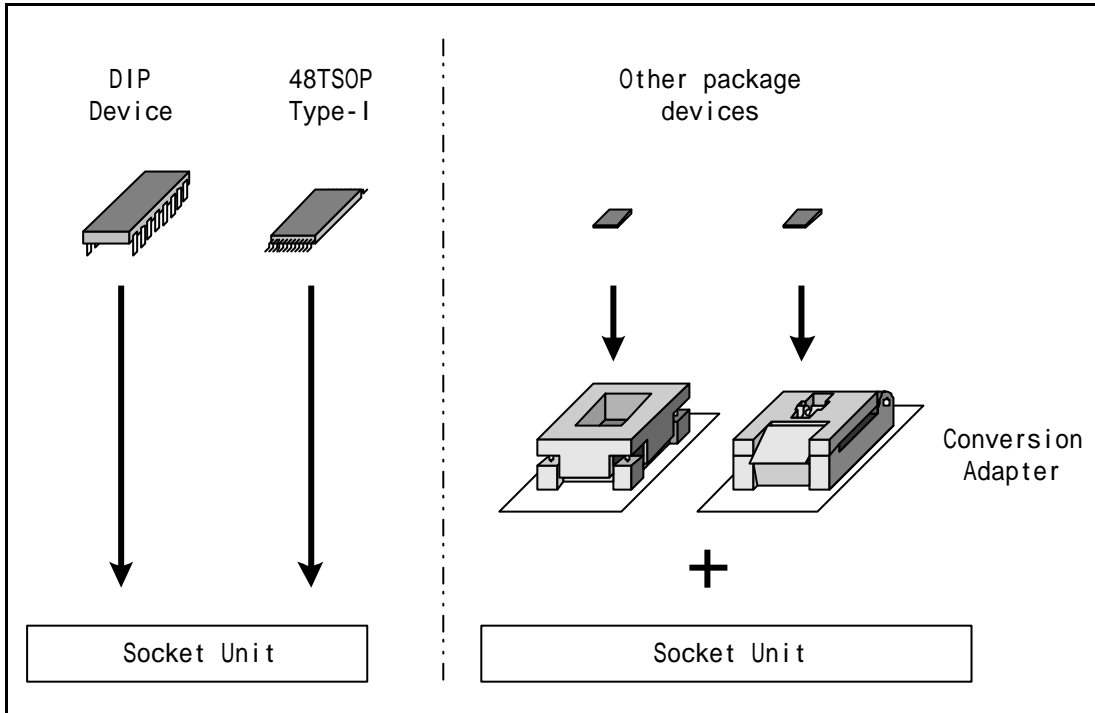

Corresponding table

Device Type	Package Type	Using Units	Setting image	
8bit	DIP	M1894+SU08-42D+PROM	○	-
	Others	“ + “ +Conversion adapter+PROM	-	○
16bit(JEDEC)	DIP	M1894+SU16-42D+PROM	○	-
	Others	“ + “ +Conversion adapter+PROM	-	○
16bit(EIAJ)	DIP	M1894+SU16-48D+PROM	○	-
	TSOP (I)	“ +SU16-48TS+PROM	○	-
	Others	“ + SU16-48D +Conversion adapter+PROM	-	○

## Inserting a device in a socket

This is to describe how to insert a device.

DIP device

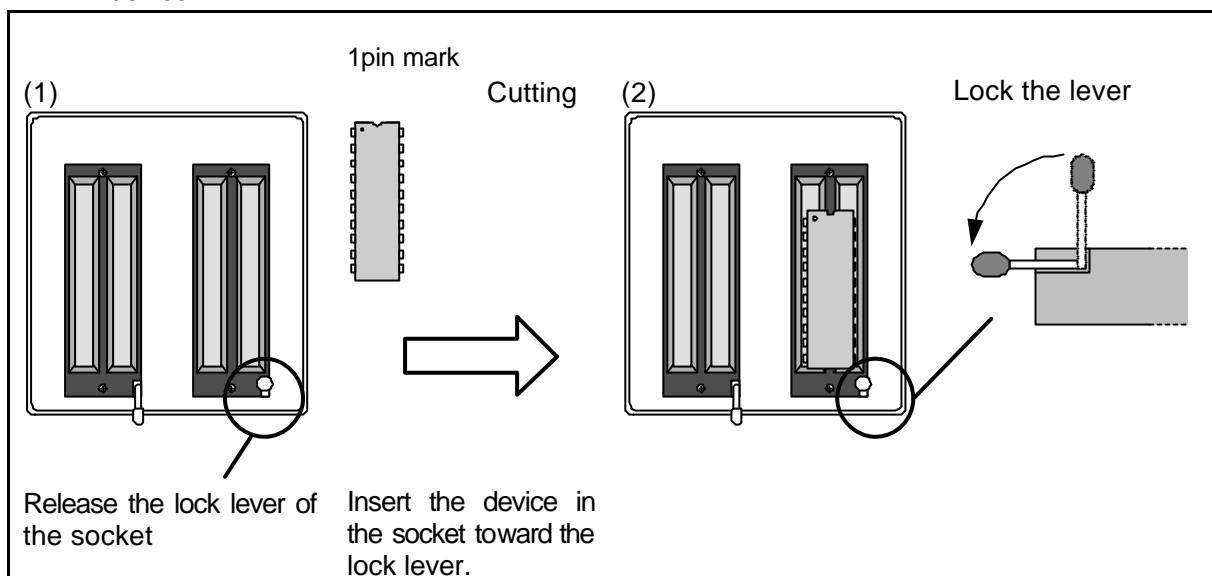

Remarks: Do not set the device while lever is locked. It may damage the socket.

Lock the lever firmly. Otherwise, error or irregular operation is occurred.

In this manual, "set a device" means not only inserting device in the socket, but lock the lever to fix the device on the socket.

In case of conversion adapter

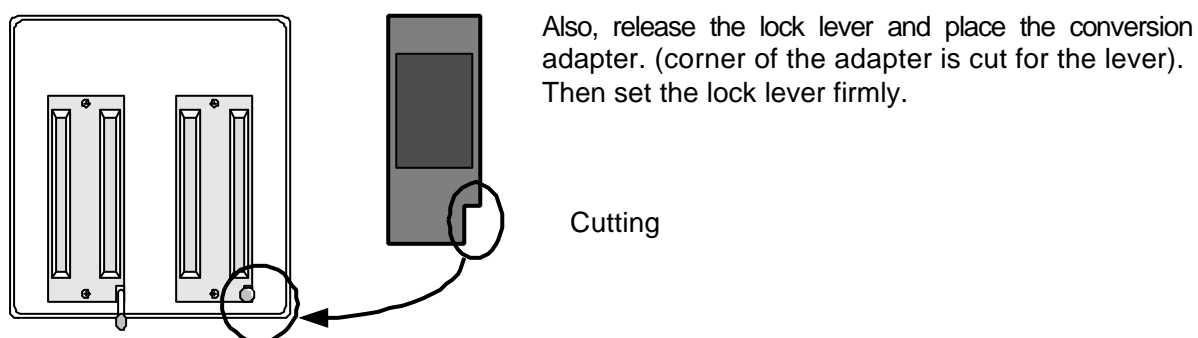

## How to read display

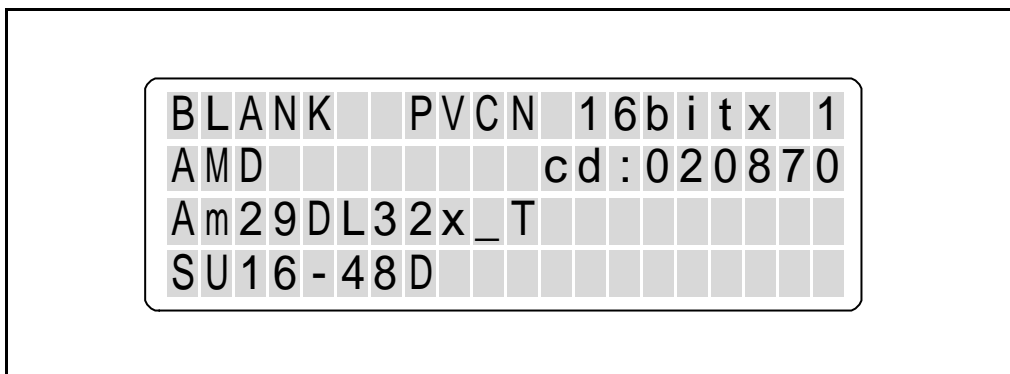

Device supplier

Device name

Type of socket unit

Device code

Basic function ("COPY", "ERASE", "BLANK", "PROG", "VERIFY", "CONT") is displayed.

~ Display of advance operation

"P": When programming address is specified, "P" is indicated. (Advance operation: Refer to PAE)

"S": When set programming mode is used, "S" is indicated. (Advance operation: Refer to SET PRG MODE)

"V": When the number of "VERIFY" is changed, "V" is indicated.

(Advance operation: Refer to VERIFY PATTERN)

"C": When VCC is changed, "C" READ is indicated. (Advance operation: Refer to READ VCC)

"N": When sector protect is valid, "N", "P", "U" is indicated. (Advance operation: Refer to PROTECT MODE)

Data length

Data length of the targeted device and the status of "Set Programming" are indicated.

(Advance operation: Refer to SET PRG MODE)

## Key operation on initial display

This is to explain key operation on initial display

Execute COPY, ERASE, BLANK, PROG, VERIFY, CONT mode and return to initial display.

It displays the total operating time of the mode from the start to the end.

It displays SUM, XCR per each socket.

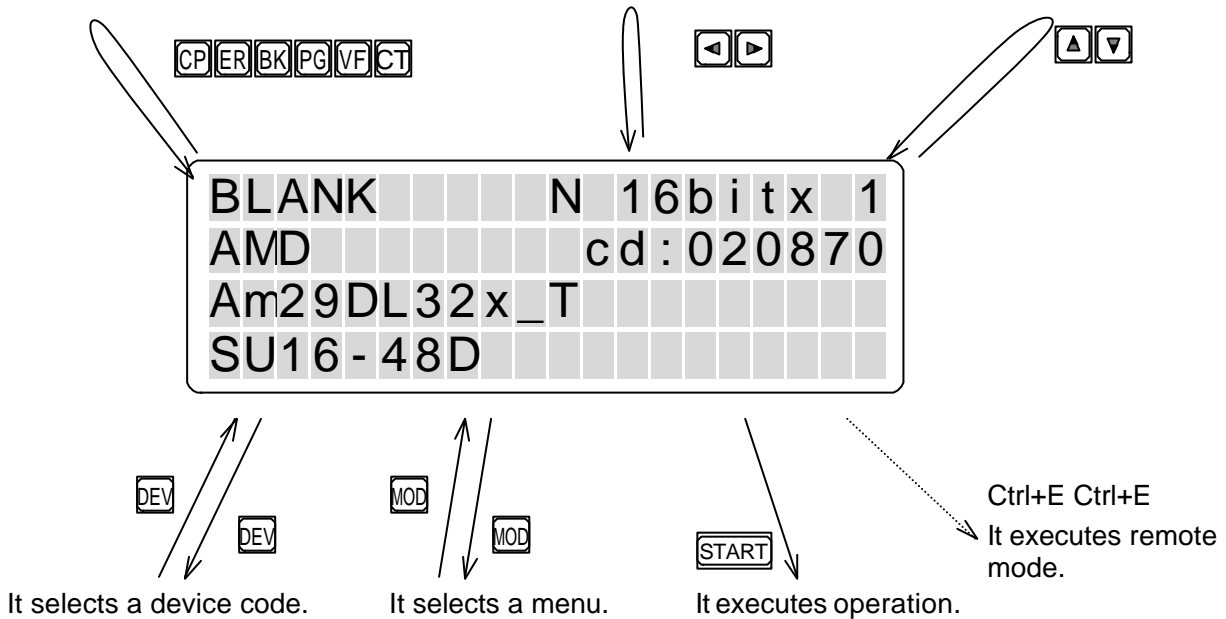

Remarks: Arrow mark in this manual shows the flow of the process of M1894.

U turns sign in this manual means that the menu returns to the initial one after completing the selected process.

\* Also, RESET key can be used to return to the initial display. : **RESET**

Warning: Do not press RESET key while ERASE, PROG, and CONT mode is in motion. It may damage the device.

## BASIC OPERATION

To program a device .....	22
Set a device code .....	23
Auto Select .....	23
Setting a device by key operation .....	25
COPY (copying device data) .....	27
ERASE (Erase data in a device) .....	29
BLANK (To check the erase status of the device data) .....	31
PROG (To program device data) .....	33
VERIFY ( To verify the device data and the buffer memory ) .....	35
CONT (Continuous mode) .....	38
Remarks .....	41
Contact check .....	41
ID check .....	42
Display of operating time .....	43
Display of SUM and XOR .....	43

## To program a device

The following is the operation flow to program a device on M1894,

Set socket unit(s) on M1894 (For the operation : Please refer to Socket Unit)

Select a device code (This chapter : Please refer to Set Device Code)

Prepare programming data in the buffer memory of M1894.

Step1 : Copy a master ROM (This chapter : Please refer to COPY )

Step2 : Transfer data through data communication  
(Communication Feature: Please refer to data transfer)

Step3 : Edit data in buffer memory (Memory : Please refer to Buffer DUMP/EDIT)

Select Program/Continuous operating mode (This chapter : Please refer to PROG, CONT)

Set a device in a socket (For the operant : Please refer to Set a Device in a Socket)

Press START key

Execute contact check on each pin of the device (automatic)  
(This chapter : Please refer to remarks )

Execute ID check of the device (automatic)  
(This chapter : Please refer to remarks )

Program a device (automatic )

End ((The result is displayed. ))

## Set a device code

This is an operation to set a targeted device. In this manual, this operation is called, "Set a Device Code". By setting device code, particular information to program the targeted device is set on the programmer. Proprietary device code of Minato programmer is targeted for each device. These codes are unique for Minato programmer and they are not applicable for other programmers or device suppliers. In M1894, there are two methods to set device: One is auto select and the other is manual key operation.

### Autoselect

The auto select function of the programmer enables to read and search the device ID of each device. When the device code is found, the targeted device is displayed. When several devices are matched to the device ID which is searched by the programmer, all the applicable devices are displayed. Select the targeted device among them. When either SU16-48D or SU16-48TS is installed, auto select function becomes available.

Example: Set AMD Am29DL323T (3v system 32M)

<p><b>DEV</b> &gt; <b>START</b></p> <p>After setting a device on the socket #1, press DEV key. Then the display shows the message as identified on the right. Press START to execute auto select</p>	<pre> Manufacture Select [ALLIANCE  ] AMD ATMEL           </pre>
<p>[Searching Display] Device ID is search on Vcc 1.8V system.</p> <p>The search is accomplished the following sequence: 1.8 3.0 5.0v</p>	<pre> Device AutoSelect Vcc=1.80V Searching...           [xxxx]           </pre>
<p><b>ENT</b></p> <p>No match is found at Vcc 1.8. Then it is searched at Vcc 3.0v. Press ENT key to continue.</p>	<pre> Device AutoSelect Do you want to search h at 3.0V ? Search -&gt; [ENT]key           </pre>
<p><b>START</b></p> <p>A warning message is displayed. To continue, press START key.</p>	<pre> Warning it Damages t he device if voltage is inappropriate. OK -&gt; [START]key           </pre>

<p><b>ENT</b></p> <p>Matched device is AM29DL32x_T. Press ENT key.</p>	<pre> Device AutoSelect [Am29DL32xT ] . . more . . </pre>
<p><b>START</b></p> <p>Confirm the setting and press START key if it is OK.</p>	<pre> Select device AMD cd:020870 Am29DL32x_T OK -&gt; [START] key </pre>
<p>M1894 displays the initial display and end the operation.</p> <p>When the device code is change, the default mode is turned to BLANK.</p>	<pre> BLANK N 16bitx 1 AMD cd:020870 Am29DL32x_T SU16-48D </pre>

Remarks: The search of 1.8v is included in the search of 3v system and it is the same as 5v system. If multiple devices are matched without matching the targeted device, move the cursor to “more” and press ENT key to continue the search.

When the targeted device is not searched by auto select, set the device by manual key operation.

## Setting a device by key operation

This operation is to select the targeted device. We called it Set a Device Code. Particular device code is assigned to each device that is supported on M1894. This code is unique for Minato and it is not applicable for other programmers.

As automatic device ID is not available on M1894, this operation is required on M1894.

The operator following the display message and select a device by the following sequence: Supplier      Size  
Part number of the device

Remarks: When a socket unit is not installed or wrong socket unit is installed, the targeted device is not displayed.

“To select AMD, 32M, AM29DL32x\_T” (Socket Unit : SU16-48D)

<p>DEV &gt; ▲ ▼</p> <p>Move the cursor to “AMD”</p>	<p>Manufacture Select</p> <p>[ ALLIANCE      ]</p> <p>AMD</p> <p>ATMEL</p>
<p>ENT &gt; ▲ ▼ ◀ ▶</p> <p>Move the cursor to “32M”</p>	<p>Capacity Select</p> <p>1M      2M</p> <p>4M      8M</p> <p>16M      [ 32M      ]</p>
<p>ENT &gt; ▲ ▼</p> <p>Move the cursor to “AM29DL32x_T”</p>	<p>Device Select</p> <p>[ Am29DL32x_T      ]</p> <p>Am29DL32x_B</p> <p>Am29DS323_T</p>
<p>ENT &gt; [STAR]</p> <p>Confirm the setting and press START key if it is OK.</p>	<p>Select device</p> <p>AMD      cd:020870</p> <p>Am29DL32x_T</p> <p>OK -&gt; [START] key</p>



M1894 displays the initial display and end the operation.

When the device code is change, the default mode is turned to BLANK.

```
BLANK   N 16bitx 1
AMD     cd:020870
Am29DL32x_T
SU16-48D
```

Remarks: When a socket unit is not installed, the following message is displayed. Even if START key is pressed at this stage, M1894 does not run displaying "Device Not Selected".

```
BLANK   - - b i t x - -
        cd: - - - - -
```

## COPY - Copying device data -

Reading data in a device and store it in the buffer memory of M1894.  
Is used to copy data of the master ROM.

<p><b>CP</b></p> <p>Set the device to copy in the socket #1.</p> <p><b>STAR</b> : Execute "COPY"</p>	<table border="1"> <tr><td>COPY</td><td></td><td></td><td></td><td></td><td></td><td></td><td></td><td></td><td></td><td>N</td><td>1</td><td>6</td><td>b</td><td>i</td><td>t</td><td>x</td><td>1</td></tr> <tr><td>AMD</td><td></td><td></td><td></td><td></td><td></td><td></td><td></td><td></td><td></td><td>cd</td><td>:</td><td>0</td><td>2</td><td>0</td><td>8</td><td>7</td><td>0</td></tr> <tr><td>Am</td><td>2</td><td>9</td><td>D</td><td>L</td><td>3</td><td>2</td><td>x</td><td>_</td><td>T</td><td></td><td></td><td></td><td></td><td></td><td></td><td></td><td></td></tr> <tr><td>SU</td><td>1</td><td>6</td><td>-</td><td>4</td><td>8</td><td>D</td><td></td><td></td><td></td><td></td><td></td><td></td><td></td><td></td><td></td><td></td><td></td></tr> </table>	COPY										N	1	6	b	i	t	x	1	AMD										cd	:	0	2	0	8	7	0	Am	2	9	D	L	3	2	x	_	T									SU	1	6	-	4	8	D											
COPY										N	1	6	b	i	t	x	1																																																								
AMD										cd	:	0	2	0	8	7	0																																																								
Am	2	9	D	L	3	2	x	_	T																																																																
SU	1	6	-	4	8	D																																																																			

Remarks: When COPY is completed, M1894 starts VERIFY.

To execute COPY once again, it is not necessary to press COPY. Presses only START to execute COPY in such case.

Warning: Even if a device is set on the other socket than #1, the data cannot be copied. It is necessary to set a device on #1 socket. The contact check and the result of this operation are based on the status of #1. That of other sockets is ignored.

Cheek the sum of the master ROM in advance.

Little endian method is applicable for M1894. (Memory : Please refer to little endian)

Targeted COPY socket is different when SET PRG mode is used.

(Advance mode : Please refer to "Set Prgmode")

### Display result

#### When Passed

<p>LED</p> <p>#1 : Green light is lit</p> <p>#2- 8: Red light is lit</p> <p>BUZZER</p> <p>: Short beep</p>	<p>Display: Check sum and XOR are displayed</p> <table border="1"> <tr><td>COPY</td><td></td><td></td><td></td><td></td><td></td><td></td><td></td><td></td><td></td><td>N</td><td>1</td><td>6</td><td>b</td><td>i</td><td>t</td><td>x</td><td>1</td></tr> <tr><td>AMD</td><td></td><td></td><td></td><td></td><td></td><td></td><td></td><td></td><td></td><td>cd</td><td>:</td><td>0</td><td>2</td><td>0</td><td>8</td><td>7</td><td>0</td></tr> <tr><td>Am</td><td>2</td><td>9</td><td>D</td><td>L</td><td>3</td><td>2</td><td>x</td><td>_</td><td>T</td><td></td><td></td><td></td><td></td><td></td><td></td><td></td><td></td></tr> <tr><td>SUM</td><td>:</td><td>x</td><td>x</td><td>x</td><td>x</td><td>XOR</td><td>:</td><td>x</td><td>x</td><td></td><td></td><td></td><td></td><td></td><td></td><td></td><td></td></tr> </table>	COPY										N	1	6	b	i	t	x	1	AMD										cd	:	0	2	0	8	7	0	Am	2	9	D	L	3	2	x	_	T									SUM	:	x	x	x	x	XOR	:	x	x								
COPY										N	1	6	b	i	t	x	1																																																								
AMD										cd	:	0	2	0	8	7	0																																																								
Am	2	9	D	L	3	2	x	_	T																																																																
SUM	:	x	x	x	x	XOR	:	x	x																																																																

#### When Failed

<p>LED</p> <p>#1-8 : Red light is lit</p> <p>BUZZER</p> <p>: Continuous short beep</p>	<p>Display: FAIL address, memory data and Device deta are displayed</p> <table border="1"> <tr><td>COPY</td><td></td><td></td><td></td><td></td><td></td><td></td><td></td><td></td><td></td><td>N</td><td>1</td><td>6</td><td>b</td><td>i</td><td>t</td><td>x</td><td>1</td></tr> <tr><td>AMD</td><td></td><td></td><td></td><td></td><td></td><td></td><td></td><td></td><td></td><td>cd</td><td>:</td><td>0</td><td>2</td><td>0</td><td>8</td><td>7</td><td>0</td></tr> <tr><td>Am</td><td>2</td><td>9</td><td>D</td><td>L</td><td>3</td><td>2</td><td>x</td><td>_</td><td>T</td><td></td><td></td><td></td><td></td><td></td><td></td><td></td><td></td></tr> <tr><td>x</td><td>x</td><td>x</td><td>x</td><td>x</td><td>x</td><td>x</td><td>x</td><td>x</td><td>x</td><td>x</td><td>x</td><td>x</td><td>x</td><td>x</td><td>x</td><td>x</td><td>x</td></tr> </table>	COPY										N	1	6	b	i	t	x	1	AMD										cd	:	0	2	0	8	7	0	Am	2	9	D	L	3	2	x	_	T									x	x	x	x	x	x	x	x	x	x	x	x	x	x	x	x	x	x
COPY										N	1	6	b	i	t	x	1																																																								
AMD										cd	:	0	2	0	8	7	0																																																								
Am	2	9	D	L	3	2	x	_	T																																																																
x	x	x	x	x	x	x	x	x	x	x	x	x	x	x	x	x	x																																																								

Right and Left key to display operating time

(This chapter : Please refer to remarks)

Flow chart of "COPY" mode operation

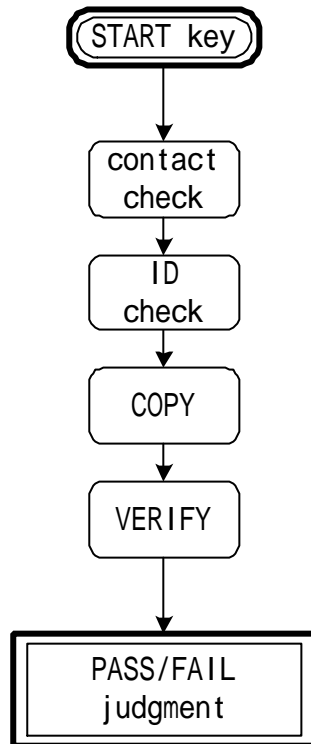

## ERASE - Erase data in a device -

This is to erase memory data in a device

<div style="border: 1px solid black; padding: 2px; display: inline-block; margin-bottom: 10px;">ER</div> <div style="border: 1px solid black; padding: 2px; display: inline-block;">STAR</div> : Execute "ERASE"	<table border="1" style="border-collapse: collapse; width: 100%; height: 100%;"> <tr><td>ERASE</td><td></td><td></td><td></td><td></td><td></td><td>N</td><td>1</td><td>6</td><td>b</td><td>i</td><td>t</td><td>x</td><td>1</td></tr> <tr><td>AMD</td><td></td><td></td><td></td><td></td><td></td><td>cd</td><td>:</td><td>0</td><td>2</td><td>0</td><td>8</td><td>7</td><td>0</td></tr> <tr><td>A</td><td>m</td><td>2</td><td>9</td><td>D</td><td>L</td><td>3</td><td>2</td><td>x</td><td>_</td><td>T</td><td></td><td></td><td></td></tr> <tr><td>S</td><td>U</td><td>1</td><td>6</td><td>-</td><td>4</td><td>8</td><td>D</td><td></td><td></td><td></td><td></td><td></td><td></td></tr> </table>	ERASE						N	1	6	b	i	t	x	1	AMD						cd	:	0	2	0	8	7	0	A	m	2	9	D	L	3	2	x	_	T				S	U	1	6	-	4	8	D						
ERASE						N	1	6	b	i	t	x	1																																												
AMD						cd	:	0	2	0	8	7	0																																												
A	m	2	9	D	L	3	2	x	_	T																																															
S	U	1	6	-	4	8	D																																																		

If there is any socket without device insertion among 8 sockets, "Empty Socket" is displayed in the display.

Then empty socket is indicated with red LED and stops the operation. To continue, please START key.

Remarks: When ERASE is completed, M1894 starts BLANK.

Warning: Erase mode is applicable only for EE-PROM and FLASH which can be erased electrically.

In case of E-PROM, this key is not applicable.

When erase is executed, all data in the device is changed to all "FFFFh".

(In case of 8-bit device, it is "FFh" in stead.)

Display result

When Passed

<p>LED          PASS Socket: Green light is lit          Empty Socket: Red light is lit          BUZZER                : Short beep</p>	<p>Display: End address is displayed</p> <table border="1" style="border-collapse: collapse; width: 100%; height: 100%;"> <tr><td>ERASE</td><td></td><td></td><td></td><td></td><td></td><td>N</td><td>1</td><td>6</td><td>b</td><td>i</td><td>t</td><td>x</td><td>1</td></tr> <tr><td>AMD</td><td></td><td></td><td></td><td></td><td></td><td>cd</td><td>:</td><td>0</td><td>2</td><td>0</td><td>8</td><td>7</td><td>0</td></tr> <tr><td>A</td><td>m</td><td>2</td><td>9</td><td>D</td><td>L</td><td>3</td><td>2</td><td>x</td><td>_</td><td>T</td><td></td><td></td><td></td></tr> <tr><td>x</td><td>x</td><td>x</td><td>x</td><td>x</td><td>x</td><td>x</td><td></td><td></td><td></td><td></td><td></td><td></td><td></td></tr> </table>	ERASE						N	1	6	b	i	t	x	1	AMD						cd	:	0	2	0	8	7	0	A	m	2	9	D	L	3	2	x	_	T				x	x	x	x	x	x	x							
ERASE						N	1	6	b	i	t	x	1																																												
AMD						cd	:	0	2	0	8	7	0																																												
A	m	2	9	D	L	3	2	x	_	T																																															
x	x	x	x	x	x	x																																																			

When Failed

<p>LED          PASS Socket: Green light is lit          Fail Socket: Red light is lit          Empty Socket: Red light is lit          BUZZER                : Continuous short beep</p>	<p>Display: FAIL address and memory data are displayed</p> <table border="1" style="border-collapse: collapse; width: 100%; height: 100%;"> <tr><td>ERASE</td><td></td><td></td><td></td><td></td><td></td><td>N</td><td>1</td><td>6</td><td>b</td><td>i</td><td>t</td><td>x</td><td>1</td></tr> <tr><td>AMD</td><td></td><td></td><td></td><td></td><td></td><td>cd</td><td>:</td><td>0</td><td>2</td><td>0</td><td>8</td><td>7</td><td>0</td></tr> <tr><td>A</td><td>m</td><td>2</td><td>9</td><td>D</td><td>L</td><td>3</td><td>2</td><td>x</td><td>_</td><td>T</td><td></td><td></td><td></td></tr> <tr><td>x</td><td>x</td><td>x</td><td>x</td><td>x</td><td>x</td><td>x</td><td>x</td><td>x</td><td>x</td><td></td><td></td><td></td><td></td></tr> </table>	ERASE						N	1	6	b	i	t	x	1	AMD						cd	:	0	2	0	8	7	0	A	m	2	9	D	L	3	2	x	_	T				x	x	x	x	x	x	x	x	x	x				
ERASE						N	1	6	b	i	t	x	1																																												
AMD						cd	:	0	2	0	8	7	0																																												
A	m	2	9	D	L	3	2	x	_	T																																															
x	x	x	x	x	x	x	x	x	x																																																

Right and Left key to display operating time

(This chapter : Please refer to remarks)

Flow chart of "ERASE" mode operation

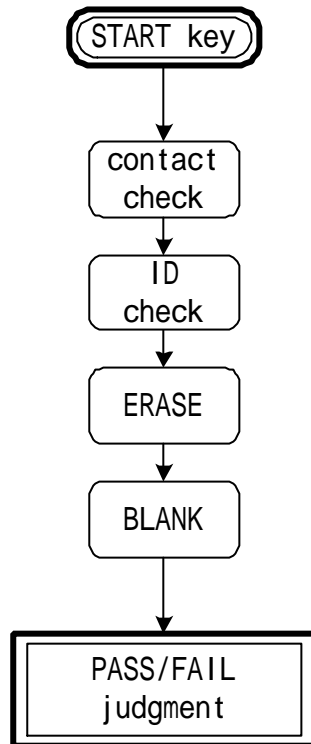

## BLANK - To check the erase status of the device data -

This is to check if the memory data of the device is BLANK.

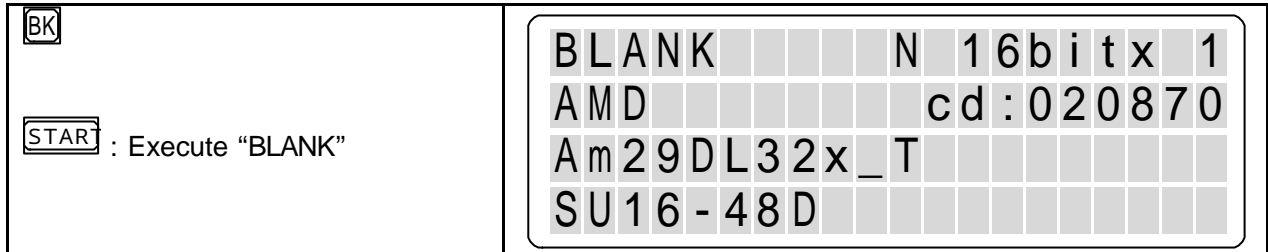

If there is any socket without device insertion among 8 sockets, "Empty Socket" is displayed in the display.

Then empty socket is indicated with red LED and stops the operation. To continue, please START key.

Remarks: To execute BLANK once again, it is not necessary to press BLANK. Presses only START to execute BLANK in such case.

### BLANK DATA:

8bit device : "FFh"

16bit device : "FFFFh"

### Display result

#### When Passed

<p>LED</p> <p>PASS Socket: Green light is lit</p> <p>Empty Socket: Red light is lit</p> <p>BUZZER</p> <p>: Short beep</p>	<p>Display: End address is displayed</p> <table border="1" style="border-collapse: collapse; width: 100%; height: 100%;"> <tr><td>BLANK</td><td></td><td></td><td></td><td></td><td></td><td>N</td><td>1</td><td>6</td><td>b</td><td>i</td><td>t</td><td>x</td><td>1</td></tr> <tr><td>AMD</td><td></td><td></td><td></td><td></td><td></td><td>cd</td><td>:</td><td>0</td><td>2</td><td>0</td><td>8</td><td>7</td><td>0</td></tr> <tr><td>Am</td><td>2</td><td>9</td><td>DL</td><td>3</td><td>2</td><td>x</td><td>_</td><td>T</td><td></td><td></td><td></td><td></td><td></td></tr> <tr><td>x</td><td>x</td><td>x</td><td>x</td><td>x</td><td>x</td><td>x</td><td></td><td></td><td></td><td></td><td></td><td></td><td></td></tr> </table>	BLANK						N	1	6	b	i	t	x	1	AMD						cd	:	0	2	0	8	7	0	Am	2	9	DL	3	2	x	_	T						x	x	x	x	x	x	x							
BLANK						N	1	6	b	i	t	x	1																																												
AMD						cd	:	0	2	0	8	7	0																																												
Am	2	9	DL	3	2	x	_	T																																																	
x	x	x	x	x	x	x																																																			

#### When Failed

<p>LED</p> <p>PASS Socket: Green light is lit</p> <p>Fail Socket: Red light is lit</p> <p>Empty Socket: Red light is lit</p> <p>BUZZER</p> <p>: Continuous short beep</p>	<p>Display: FAIL address and memory data are displayed</p> <table border="1" style="border-collapse: collapse; width: 100%; height: 100%;"> <tr><td>BLANK</td><td></td><td></td><td></td><td></td><td></td><td>N</td><td>1</td><td>6</td><td>b</td><td>i</td><td>t</td><td>x</td><td>1</td></tr> <tr><td>AMD</td><td></td><td></td><td></td><td></td><td></td><td>cd</td><td>:</td><td>0</td><td>2</td><td>0</td><td>8</td><td>7</td><td>0</td></tr> <tr><td>Am</td><td>2</td><td>9</td><td>DL</td><td>3</td><td>2</td><td>x</td><td>_</td><td>T</td><td></td><td></td><td></td><td></td><td></td></tr> <tr><td>x</td><td>x</td><td>x</td><td>x</td><td>x</td><td>x</td><td>x</td><td>x</td><td>x</td><td></td><td></td><td></td><td></td><td></td></tr> </table>	BLANK						N	1	6	b	i	t	x	1	AMD						cd	:	0	2	0	8	7	0	Am	2	9	DL	3	2	x	_	T						x	x	x	x	x	x	x	x	x					
BLANK						N	1	6	b	i	t	x	1																																												
AMD						cd	:	0	2	0	8	7	0																																												
Am	2	9	DL	3	2	x	_	T																																																	
x	x	x	x	x	x	x	x	x																																																	

Right and Left key to display operating time

(This chapter : Please refer to remarks)

Flow chart of "BLANK" mode operation

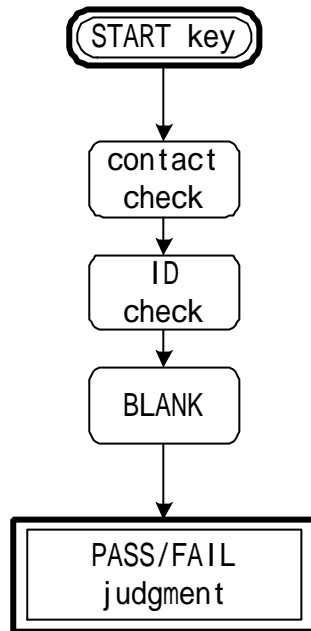

## PROG - To program device data -

This is to program the buffer memory data into the device.

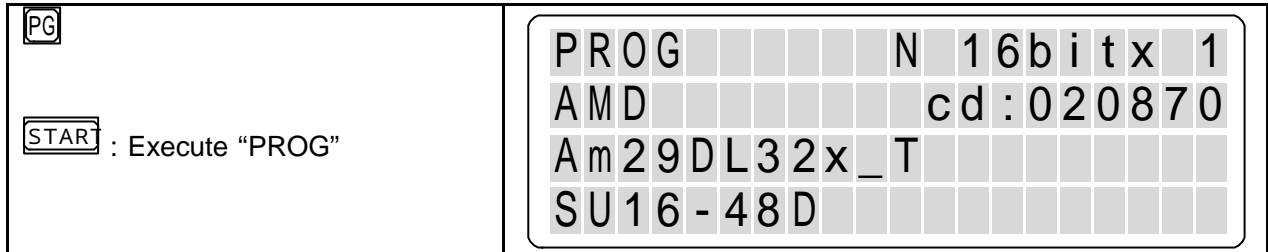

If there is any socket without device insertion among 8 sockets, "Empty Socket" is displayed in the display.

Then empty socket is indicated with red LED and stops the operation. To continue, please START key.

Remarks: When PROG is completed, M1894 starts VERIFY.

To execute PROG once again, it is not necessary to press PROG. Presses only START to execute PROG in such case.

Warning: Little endian method is applicable for M1894.

(Memory: Please refer to little endian)

Display result

When Passed

<p>LED          PASS Socket: Green light is lit          Empty Socket: Red light is lit          BUZZER          : Short beep</p>	<p>Display: Check sum and XOR are displayed</p> <table border="1"> <tr><td>P</td><td>R</td><td>O</td><td>G</td><td></td><td></td><td></td><td></td><td>N</td><td>1</td><td>6</td><td>b</td><td>i</td><td>t</td><td>x</td><td>1</td></tr> <tr><td>A</td><td>M</td><td>D</td><td></td><td></td><td></td><td></td><td></td><td>c</td><td>d</td><td>:</td><td>0</td><td>2</td><td>0</td><td>8</td><td>7</td><td>0</td></tr> <tr><td>A</td><td>m</td><td>2</td><td>9</td><td>D</td><td>L</td><td>3</td><td>2</td><td>x</td><td>_</td><td>T</td><td></td><td></td><td></td><td></td><td></td></tr> <tr><td>S</td><td>U</td><td>M</td><td>:</td><td>x</td><td>x</td><td>x</td><td>x</td><td>X</td><td>O</td><td>R</td><td>:</td><td>x</td><td>x</td><td></td><td></td><td></td></tr> </table>	P	R	O	G					N	1	6	b	i	t	x	1	A	M	D						c	d	:	0	2	0	8	7	0	A	m	2	9	D	L	3	2	x	_	T						S	U	M	:	x	x	x	x	X	O	R	:	x	x			
P	R	O	G					N	1	6	b	i	t	x	1																																																				
A	M	D						c	d	:	0	2	0	8	7	0																																																			
A	m	2	9	D	L	3	2	x	_	T																																																									
S	U	M	:	x	x	x	x	X	O	R	:	x	x																																																						

When Failed

<p>LED          PASS Socket: Green light is lit          Fail Socket: Red light is lit          Empty Socket: Red light is lit          BUZZER          : Continuous short beep</p>	<p>Display: FAIL address and memory data are displayed</p> <table border="1"> <tr><td>P</td><td>R</td><td>O</td><td>G</td><td></td><td></td><td></td><td></td><td>N</td><td>1</td><td>6</td><td>b</td><td>i</td><td>t</td><td>x</td><td>1</td></tr> <tr><td>A</td><td>M</td><td>D</td><td></td><td></td><td></td><td></td><td></td><td>c</td><td>d</td><td>:</td><td>0</td><td>2</td><td>0</td><td>8</td><td>7</td><td>0</td></tr> <tr><td>A</td><td>m</td><td>2</td><td>9</td><td>D</td><td>L</td><td>3</td><td>2</td><td>x</td><td>_</td><td>T</td><td></td><td></td><td></td><td></td><td></td></tr> <tr><td>x</td><td>x</td><td>x</td><td>x</td><td>x</td><td>x</td><td>x</td><td>x</td><td>x</td><td>x</td><td>x</td><td></td><td></td><td></td><td></td><td></td></tr> </table>	P	R	O	G					N	1	6	b	i	t	x	1	A	M	D						c	d	:	0	2	0	8	7	0	A	m	2	9	D	L	3	2	x	_	T						x	x	x	x	x	x	x	x	x	x	x					
P	R	O	G					N	1	6	b	i	t	x	1																																																			
A	M	D						c	d	:	0	2	0	8	7	0																																																		
A	m	2	9	D	L	3	2	x	_	T																																																								
x	x	x	x	x	x	x	x	x	x	x																																																								

Right and Left key to display operating time

(This chapter: Please refer to remarks)

Flow chart of "PROG" mode operation

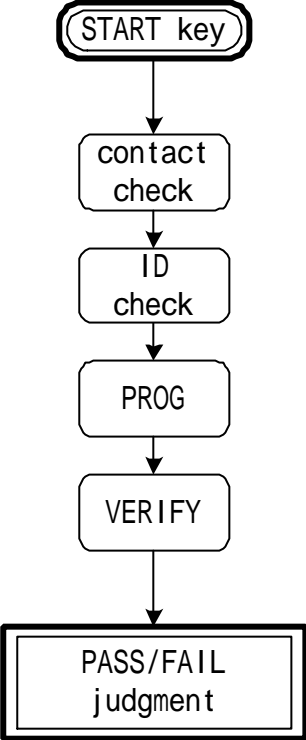

## VERIFY - To verify the device data and the buffer memory -

This is to compare and the verify the programmed data in the device and the buffer memory of M1894. Usually several patterns of checking are carried out with different conditions such as voltage.

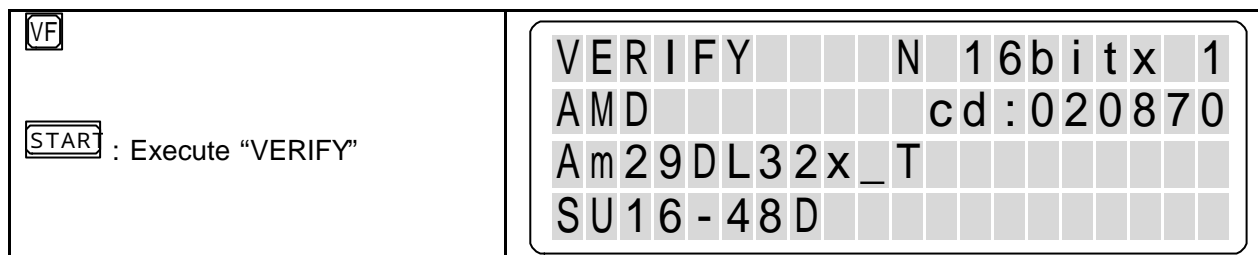

If there is any socket without device insertion among 8 sockets, "Empty Socket" is displayed in the display.

Then empty socket is indicated with red LED and stops the operation. To continue, please START key.

Remarks: To execute VERIFY once again, it is not necessary to press VERIFY. Presses only START to execute VERIFY in such case.

### VERIFY Pattern and Check condition

Pattern	Vcc Voltage	Check condition	Remark
VERIFY1	VccL	PULL-UP (to VCC)	not USE
VERIFY2	VccL	PULL-DOWN (GND)	
VERIFY3	VccH	PULL-UP (to VCC)	
VERIFY4	VccH	PULL-DOWN (GND)	not USE

Remarks: VccL (VCC Voltage-10%)

VccH (VCC Voltage+10%)

### Type of Device and Check pattern of VERIFY

Type of device	Check pattern of VERIFY	
E - P R O M	VERIFY2	VERIFY3
E E - P R O M	VERIFY2	VERIFY3
F L A S H	VERIFY2	VERIFY3

Remarks: Usually 2 or 3 sets of patterns are carried out in two cycles.

In M1894, VERIFY 1 and 4 are not applicable. For the compatibility of our other programmer, VERIFY 2 and 3 are used.

Display result

When Passed

<p>LED                  PASS Socket: Green light is lit                  Empty Socket: Red light is lit                  BUZZER                  : Short beep</p>	<p>Display: Check sum and XOR are displayed</p> <table border="1"> <tr><td>V</td><td>E</td><td>R</td><td>I</td><td>F</td><td>Y</td><td></td><td></td><td></td><td>N</td><td>1</td><td>6</td><td>b</td><td>i</td><td>t</td><td>x</td><td>1</td></tr> <tr><td>A</td><td>M</td><td>D</td><td></td><td></td><td></td><td></td><td></td><td></td><td>c</td><td>d</td><td>:</td><td>0</td><td>2</td><td>0</td><td>8</td><td>7</td><td>0</td></tr> <tr><td>A</td><td>m</td><td>2</td><td>9</td><td>D</td><td>L</td><td>3</td><td>2</td><td>x</td><td>_</td><td>T</td><td></td><td></td><td></td><td></td><td></td><td></td><td></td></tr> <tr><td>S</td><td>U</td><td>M</td><td>:</td><td>x</td><td>x</td><td>x</td><td>x</td><td>X</td><td>O</td><td>R</td><td>:</td><td>x</td><td>x</td><td></td><td></td><td></td><td></td></tr> </table>	V	E	R	I	F	Y				N	1	6	b	i	t	x	1	A	M	D							c	d	:	0	2	0	8	7	0	A	m	2	9	D	L	3	2	x	_	T								S	U	M	:	x	x	x	x	X	O	R	:	x	x				
V	E	R	I	F	Y				N	1	6	b	i	t	x	1																																																								
A	M	D							c	d	:	0	2	0	8	7	0																																																							
A	m	2	9	D	L	3	2	x	_	T																																																														
S	U	M	:	x	x	x	x	X	O	R	:	x	x																																																											

When Failed

<p>LED                  PASS Socket: Green light is lit                  Fail Socket: Red light is lit                  Empty Socket: Red light is lit                  BUZZER                  : Continuous short beep</p>	<p>Display: FAIL address and memory data are displayed</p> <table border="1"> <tr><td>V</td><td>E</td><td>R</td><td>I</td><td>F</td><td>Y</td><td></td><td></td><td></td><td>N</td><td>1</td><td>6</td><td>b</td><td>i</td><td>t</td><td>x</td><td>1</td></tr> <tr><td>A</td><td>M</td><td>D</td><td></td><td></td><td></td><td></td><td></td><td></td><td>c</td><td>d</td><td>:</td><td>0</td><td>2</td><td>0</td><td>8</td><td>7</td><td>0</td></tr> <tr><td>A</td><td>m</td><td>2</td><td>9</td><td>D</td><td>L</td><td>3</td><td>2</td><td>x</td><td>_</td><td>T</td><td></td><td></td><td></td><td></td><td></td><td></td><td></td></tr> <tr><td>x</td><td>x</td><td>x</td><td>x</td><td>x</td><td>x</td><td>x</td><td>x</td><td>x</td><td>x</td><td>x</td><td>x</td><td></td><td></td><td></td><td></td><td></td><td></td></tr> </table>	V	E	R	I	F	Y				N	1	6	b	i	t	x	1	A	M	D							c	d	:	0	2	0	8	7	0	A	m	2	9	D	L	3	2	x	_	T								x	x	x	x	x	x	x	x	x	x	x	x						
V	E	R	I	F	Y				N	1	6	b	i	t	x	1																																																								
A	M	D							c	d	:	0	2	0	8	7	0																																																							
A	m	2	9	D	L	3	2	x	_	T																																																														
x	x	x	x	x	x	x	x	x	x	x	x																																																													

Right and Left key to display operating time

(This chapter : Please refer to remarks)

Flow chart of "VERIFY" mode operation

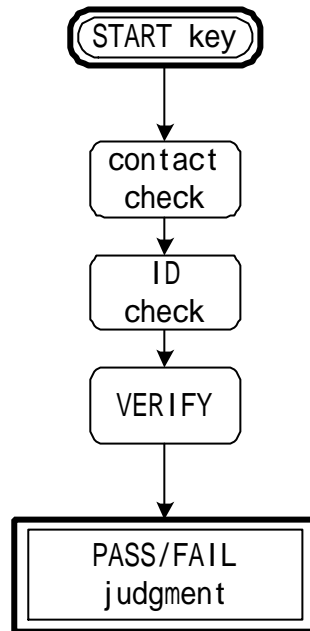

## CONT - Continuous mode -

This is an automatic continuous mode as following sequence: BLANK, ERASE, PROG, VERIFY.

<div style="border: 1px solid black; padding: 2px; display: inline-block; margin-bottom: 10px;">CT</div>  <div style="border: 1px solid black; padding: 2px; display: inline-block;">STAR</div> : Execute "CONT"	<table border="1" style="border-collapse: collapse; width: 100%; height: 100%;"> <tr><td>C</td><td>O</td><td>N</td><td>T</td><td></td><td></td><td></td><td></td><td>N</td><td>1</td><td>6</td><td>b</td><td>i</td><td>t</td><td>x</td><td>1</td></tr> <tr><td>A</td><td>M</td><td>D</td><td></td><td></td><td></td><td></td><td></td><td>c</td><td>d</td><td>:</td><td>0</td><td>2</td><td>0</td><td>8</td><td>7</td><td>0</td></tr> <tr><td>A</td><td>m</td><td>2</td><td>9</td><td>D</td><td>L</td><td>3</td><td>2</td><td>x</td><td>_</td><td>T</td><td></td><td></td><td></td><td></td><td></td></tr> <tr><td>S</td><td>U</td><td>1</td><td>6</td><td>-</td><td>4</td><td>8</td><td>D</td><td></td><td></td><td></td><td></td><td></td><td></td><td></td><td></td></tr> </table>	C	O	N	T					N	1	6	b	i	t	x	1	A	M	D						c	d	:	0	2	0	8	7	0	A	m	2	9	D	L	3	2	x	_	T						S	U	1	6	-	4	8	D								
C	O	N	T					N	1	6	b	i	t	x	1																																																			
A	M	D						c	d	:	0	2	0	8	7	0																																																		
A	m	2	9	D	L	3	2	x	_	T																																																								
S	U	1	6	-	4	8	D																																																											

If there is any socket without device insertion among 8 sockets, "Empty Socket" is displayed in the display.

Then empty socket is indicated with red LED and stops the operation. To continue, please START key.

Remarks: To execute CONT once again, it is not necessary to press CONT. Presses only START to execute CONT in such case.

Warning: If the device type is EPROM, ERASE is not executed.  
 According to the workflow it is necessary to remote failed devices.  
 Please refer to the following flow operation flow chart.

### Display result

#### When Passed

<p>LED          PASS Socket: Green light is lit          Empty Socket: Red light is lit          BUZZER          : Short beep</p>	<p>Display: Check sum and XOR are displayed</p> <table border="1" style="border-collapse: collapse; width: 100%; height: 100%;"> <tr><td>C</td><td>O</td><td>N</td><td>T</td><td></td><td></td><td></td><td></td><td>N</td><td>1</td><td>6</td><td>b</td><td>i</td><td>t</td><td>x</td><td>1</td></tr> <tr><td>A</td><td>M</td><td>D</td><td></td><td></td><td></td><td></td><td></td><td>c</td><td>d</td><td>:</td><td>0</td><td>2</td><td>0</td><td>8</td><td>7</td><td>0</td></tr> <tr><td>A</td><td>m</td><td>2</td><td>9</td><td>D</td><td>L</td><td>3</td><td>2</td><td>x</td><td>_</td><td>T</td><td></td><td></td><td></td><td></td><td></td></tr> <tr><td>S</td><td>U</td><td>M</td><td>:</td><td>x</td><td>x</td><td>x</td><td>x</td><td>X</td><td>O</td><td>R</td><td>:</td><td>x</td><td>x</td><td></td><td></td></tr> </table>	C	O	N	T					N	1	6	b	i	t	x	1	A	M	D						c	d	:	0	2	0	8	7	0	A	m	2	9	D	L	3	2	x	_	T						S	U	M	:	x	x	x	x	X	O	R	:	x	x		
C	O	N	T					N	1	6	b	i	t	x	1																																																			
A	M	D						c	d	:	0	2	0	8	7	0																																																		
A	m	2	9	D	L	3	2	x	_	T																																																								
S	U	M	:	x	x	x	x	X	O	R	:	x	x																																																					

#### When Failed

<p>LED          PASS Socket: Green light is lit          Fail Socket: Red light is lit          Empty Socket: Red light is lit          BUZZER          : Continuous short beep</p>	<p>Display: FAIL address and memory data are displayed</p> <table border="1" style="border-collapse: collapse; width: 100%; height: 100%;"> <tr><td>C</td><td>O</td><td>N</td><td>T</td><td></td><td></td><td></td><td></td><td>N</td><td>1</td><td>6</td><td>b</td><td>i</td><td>t</td><td>x</td><td>1</td></tr> <tr><td>A</td><td>M</td><td>D</td><td></td><td></td><td></td><td></td><td></td><td>c</td><td>d</td><td>:</td><td>0</td><td>2</td><td>0</td><td>8</td><td>7</td><td>0</td></tr> <tr><td>A</td><td>m</td><td>2</td><td>9</td><td>D</td><td>L</td><td>3</td><td>2</td><td>x</td><td>_</td><td>T</td><td></td><td></td><td></td><td></td><td></td></tr> <tr><td>x</td><td>x</td><td>x</td><td>x</td><td>x</td><td>x</td><td>x</td><td>x</td><td>x</td><td>x</td><td>x</td><td></td><td></td><td></td><td></td><td></td></tr> </table>	C	O	N	T					N	1	6	b	i	t	x	1	A	M	D						c	d	:	0	2	0	8	7	0	A	m	2	9	D	L	3	2	x	_	T						x	x	x	x	x	x	x	x	x	x	x					
C	O	N	T					N	1	6	b	i	t	x	1																																																			
A	M	D						c	d	:	0	2	0	8	7	0																																																		
A	m	2	9	D	L	3	2	x	_	T																																																								
x	x	x	x	x	x	x	x	x	x	x																																																								

Right and Left key to display operating time

(This chapter : Please refer to remarks)

Flow chart of "CONT" mode operation (E-PROM type)

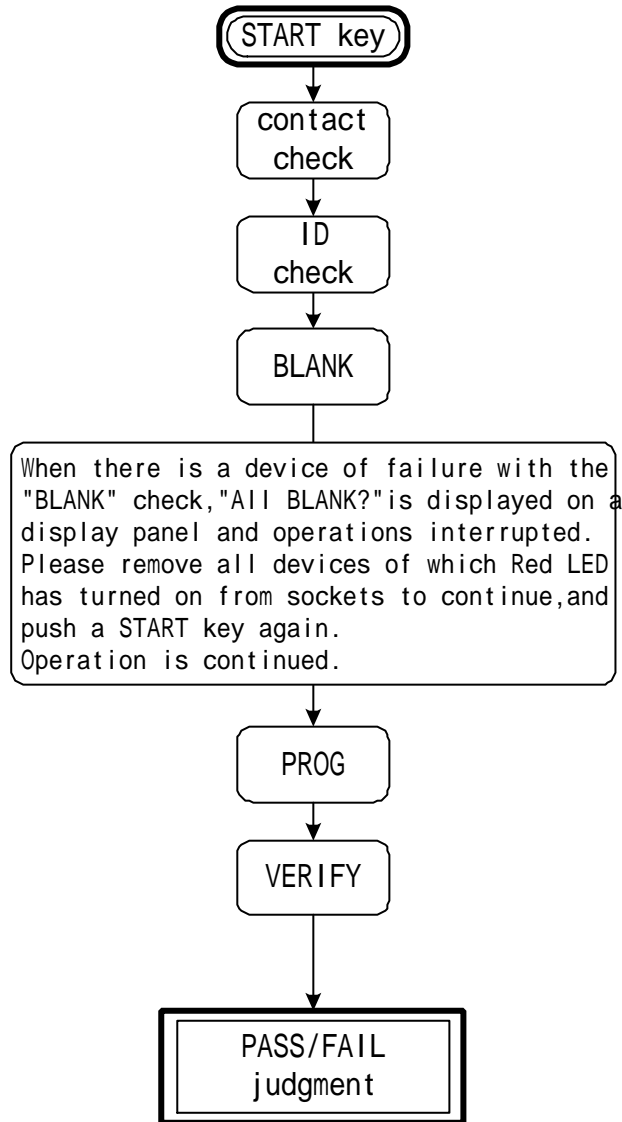

Flow chart of "CONT" mode operation (FLASH and EE-PROM type)

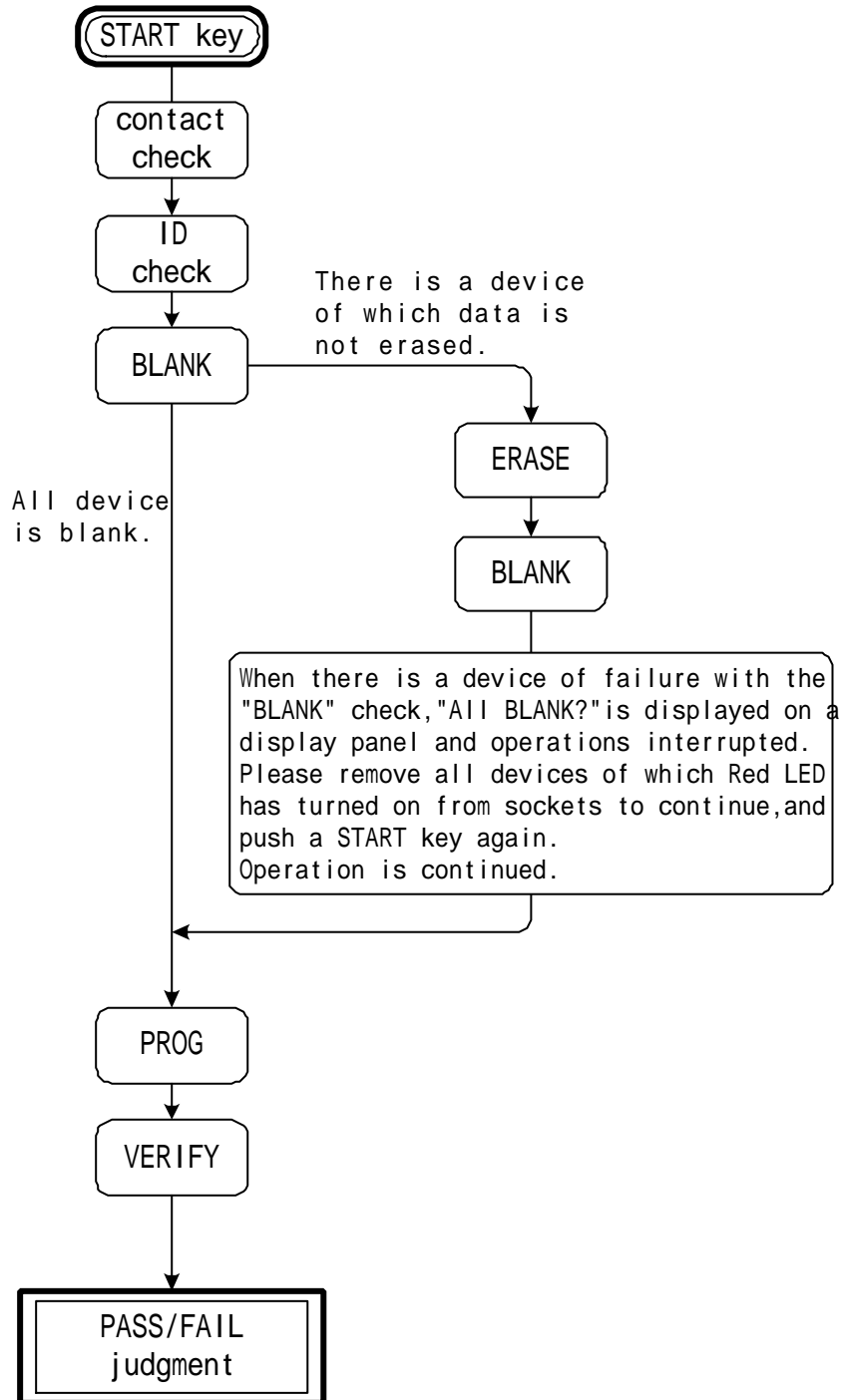

## Remark

### Contact check

Before executing "COPY, ERASE, BLANK, PROG, VERIFY, CONT", M1894 electrically checks the device if it is correctly inserted in the socket. We called it Device Contact Check.

The device may be damaged if the direction of the device is incorrect which cause over current or voltage exceeding the capacity of the device.

If the pin is not contacted and programming is executed, wrong data could be programmed in the device. The contact check of M1894 avoids such an accident.

#### Socket status and LED

No device is inserted	Red LED is lit on the corresponding socket without a device.
Check fail	Red LED is lit on the corresponding socket for check fail.
Check pass	No LED is lit on the corresponding socket for check pass.

#### Socket status and the process of M1894

All socket check pass	Execute the process
Socket with a device	Continue the contact check
Socket check fail	Continue the contact check

Remarks: **When only socket 1 to 7 is used, pressing START key skips the contact check.**

The status of "1 socket is applied for COPY. When the status of #1 socket is PASS in COPY mode, all sockets are regarded as PASS and continue the operation. The status of only the socket #1 is applied for the result of the completion of the operation.

Warning: **When check fail device is observed, do not press START key. It may damage the device.**

#### Operating mode and applicable sockets for the check

Operating mode	Applicable sockets
COPY	# 1
ERASE	# 1 – 8
BLANK	# 1 – 8
PROG	# 1 – 8
VERIFY	# 1 – 8
CONT	# 1 – 8

**Remark**

When contact error check is occurred, please check the following points.

- Device code
- The part number of socket adapter
- Lock lever of the socket
- Direction of the adapters
- Direction of the device

When all of above is not applicable, please check the following.

- Release the lever of the DIP socket and lock it once again.
- Remove the device and set in the socket once again.

If error still occurs presses RESET key and stop the operation.  
Please note the phenomena and consult with Minato authorized distributor.

**ID Check**

In 1894, device ID check is executed to avoid the mixture of different devices on the programmer. ID check is executed along with contact check at COPY and PROG, etc operation. When different devices are set on the programmer during ID check operation, M1894 displays "ID Check Error" and change the color of the LED from green to red and ends the operation.

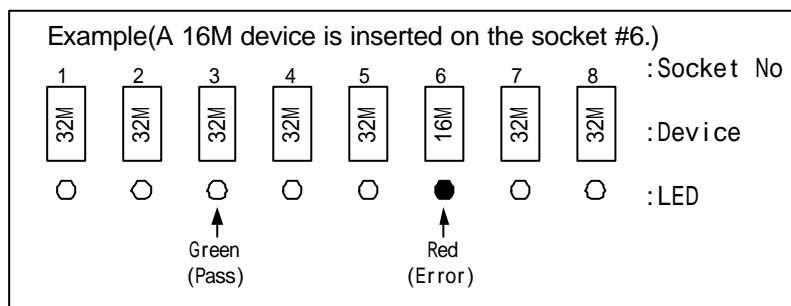
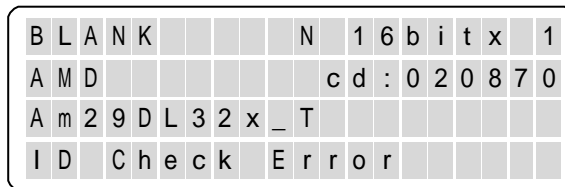

The device codes of M1894 share different devices (example Am29DL32x\_T code: 020870).This code supports DL322-324 series devices. With this code M1894 works normally as far as the device with the same ID is used. When a device with different ID code is mixed, it is recognized as a mixture of different devices and ends the operation.

## Remark

At this stage, M1894 recognizes the device ID of the socket #1 (when no device is set on the socket#1, any minimal # of the socket) as the master device. The other devices are recognized as different devices that are mixed by accident.

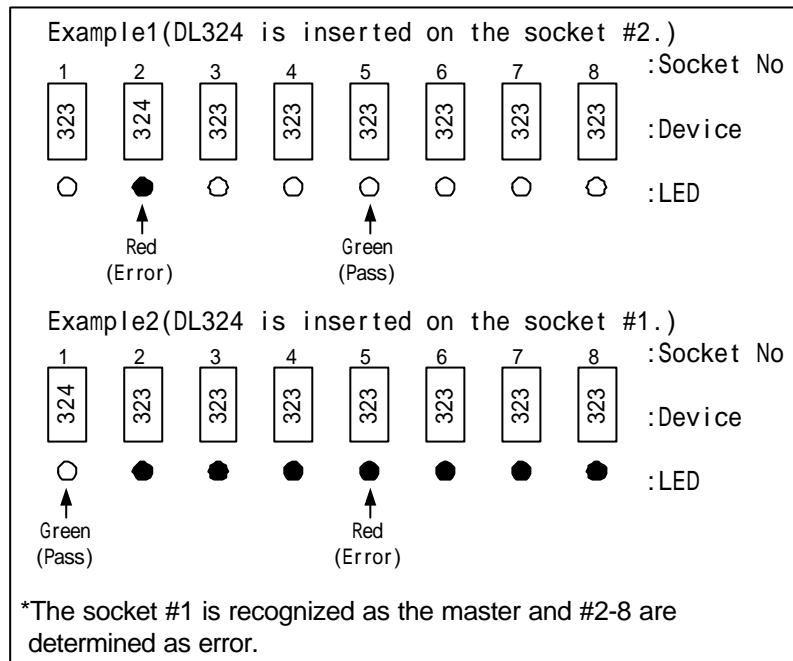

Remark: Mixture of devices with the same ID and different Vcc can not be recognized.

### Display of operating time

When each operation such as COPY, BLANK, ETC is completed, by pressing LEFT and Right keys to display the total time of the operation from the start to the end. The operating time is renewed after each operation. The time is cleared and the message is changed to “-” when the device is changed or other operation key (such as COPY, BLANK, etc) is pressed.

### Display of SUM and XOR

When each operation (such as COPY, BLANK, etc) is completed, by pressing up/down arrow key let the display shows Check SUM and XOR. By keep pressing up/down key, the socket number scrolls. Hit the key several times until the targeted socket is displayed. When “Set Prg mode” is used, different time may be displayed due to the difference of the data in each socket. When it is not used, the same data is displayed.

## ADVANCE OPERATION MODE

Advance operation mode .....	45
Using menu .....	45
List of menu .....	46
PAE (Specify operating address of the device) .....	47
Read VCC (Change device read voltage) .....	48
Verify Pattern (Changing the number of verify) .....	49
ID Check (Setting of ID Check) .....	50
Protect mode (Setting of device data protect mode) .....	51
Protect setting (To change protect setting for protected data) .....	54
Repeat mode (Setting of repeat mode) .....	55
Set Prg mode (Programming different data on multiple device) .....	56

## Advance operation mode

The most of functions for basic programming are covered in the former chapter. Sometimes you may need to use advance function such as memory data edit to change the operating condition of the device and communication setting. This is to explain these advance operations and it's applications.

### Using menu

All the function and it's setting of M1894 is summarized in the function table called "Main Menu".

#### Recalling Main Menu

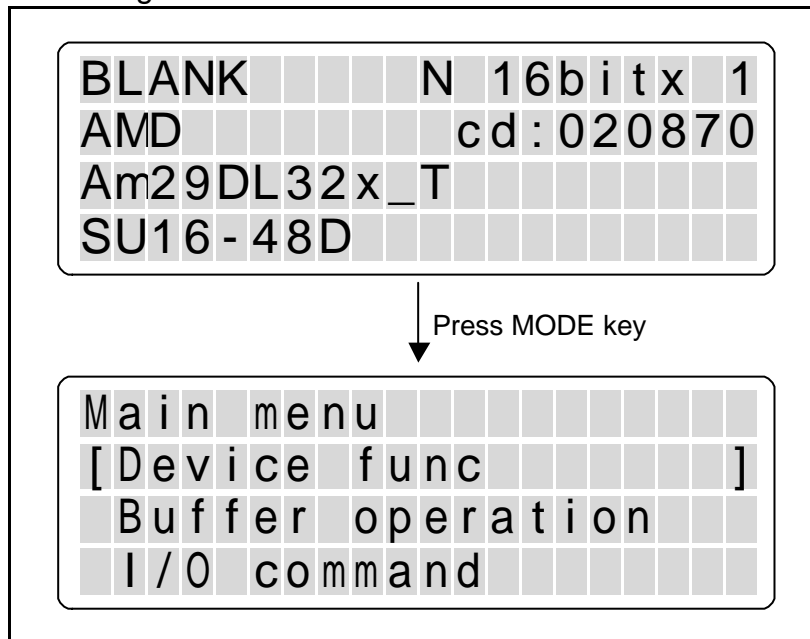

#### Items and out outlines

Title	Outlines
"Device Func"	Summarizes the operating environment of a device
"Buffer Operation"	Summarizes the function of memory operation
"I/O Command"	Summarizes the function of data transfer
"System Config"	Summarizes the function of system environment
"Remote mode"	Summarizes the function of remote mode of the main unit

#### Key operation of the Menu display

Key	Process
Up/Down key	Move cursor
ENT key	Select the pointed area by the cursor and go to the next step
DEV key	Go back to the former display for a selection
MODE key	Go to initial display

## List of menu

List 1	List 2	Functions	Page
Device func	Set Prg mode	Program different data in multiple devices	56
	PAE mode	Specify operating address of a device	47
	Read VCC	Chang device read voltage	48
	Verify pattern	Change the number of verify	49
	ID Check	Set the mode of ID check	50
	Protect mode	Set device data protection	51
	Repeat mode	Set repeat operation	55
Buffer operation	Buffer init	Initialize buffer memory data	62
	Buffer DUMP/EDIT	Dump and Edit buffer memory data	63
	Byte swap	Execute byte swap (per byte)	64
	Word swap	Execute data swap (per data)	65
	Check sum	Calculate the sum of the buffer memory	66
	Protect setting	Change the protect setting of device data	54
I/O Command	Data SR In	Data transfer (Input: SERIAL I/F )	75
	Data SR Out	Data transfer (Output: SERIAL I/F )	76
	Protect SR In	Data transfer (Input: Protect data: SERIAL I/F )	77
	Protect SR Out	Data transfer (Output: Protect data: SERIAL I/F )	78
System config	RS config	Setting of RS232C	73
	Data format	Setting of data a format	74
	Devchk/BZ/LED	Setting of device check, buzzer, LED	68
	Version display	Checking system version, memory size	69
	System update	Upgrade system version	70
Remote mode	Remote	Execute remote mode	83
	Remote config	Setting the configuration of remote mode	81
	IF Select	Select an interface	80

## PAE - Specify operating address of the device -

M1894 is designed to access all address of the device. Also, you can specify the operating address of particular devices (PAE MODE-Program Address Entry)

The following three parameters can be set in PAE mode.

“Dev start”: Operating start address (Device)

“Dev end” : Operating end address (Device)

“Buf start” : Operating start address (Buffer memory)

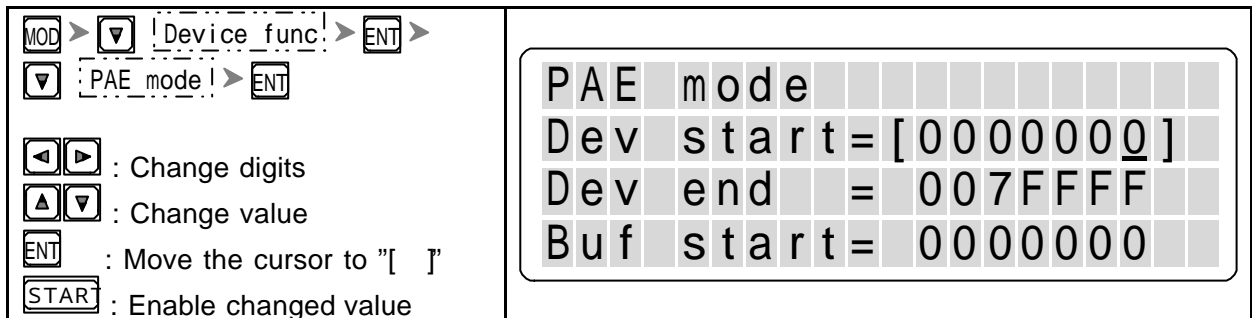

Warning: The unit of device address is the same as the data length of the device.

The unit of buffer address is fixed as one byte (8 bits). Please make a note of this especially for 16-bit device.

When device code is changed and power is turned on/off, it is changed to the default.

Remarks: The last two digits of address can not be changed on the device supporting page programming mode.

Some device prohibits to use a part of the address.

When address is changed, “P” for this mode is indicated on the display panel.

(Please refer to how to read the display )

### •PAE Image

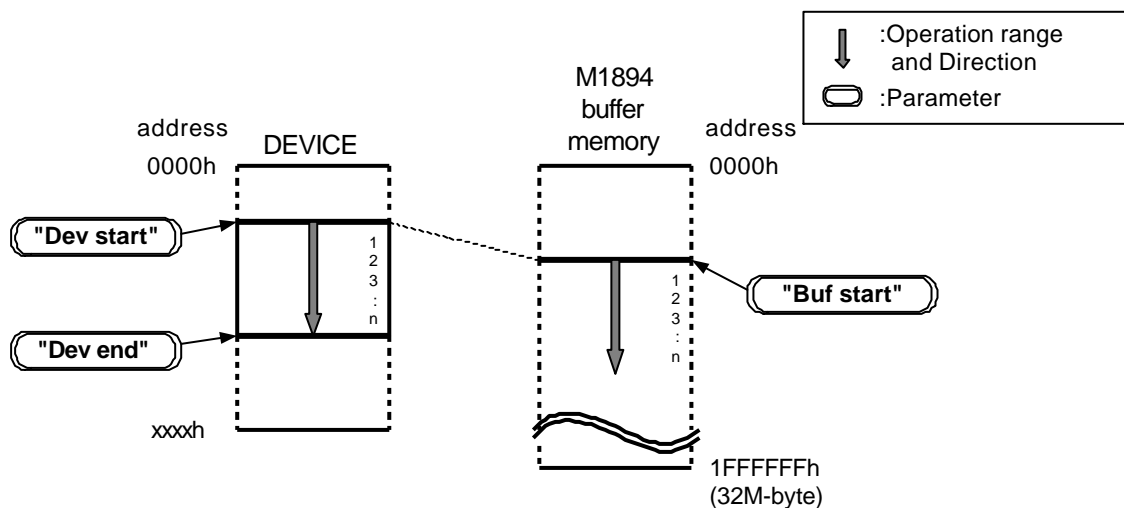

## Read Vcc - Change device read voltage -

Usually voltage applied to the device for BLANK and VERIFY check is set with  $\pm 10\%$  based on VCC voltage of COPY. These checks are targeted for different purpose. Sometimes some devices require more severe read and other checks and vice versa.

Default value (Standard value: VCC voltage for copy)

- BLANK : Standard value -10%
- VERIFY(L) : Standard value -10%
- VERIFY(H) : Standard value +10%

<div style="border: 1px dashed gray; padding: 2px;">                 MOD &gt; ▾ Device func &gt; ENT &gt;             </div> <div style="border: 1px dashed gray; padding: 2px;">                 ▾ Read VCC   &gt; ENT             </div> <p>                 ▲ ▾ : Change value                  ENT : Move the cursor to "[ ]"                  STAR : Enable changed value             </p>	<table border="1" style="width: 100%; border-collapse: collapse; text-align: center;"> <tr> <td>Read</td><td>Vcc</td><td>Select</td><td></td><td></td><td></td><td></td><td></td> </tr> <tr> <td>BLANK</td><td></td><td>:</td><td>[</td><td>4.50</td><td>V]</td><td></td><td></td> </tr> <tr> <td>VERIFY_L</td><td></td><td>:</td><td></td><td>4.50</td><td>V</td><td></td><td></td> </tr> <tr> <td>VERIFY_H</td><td></td><td>:</td><td></td><td>5.50</td><td>V</td><td></td><td></td> </tr> </table>	Read	Vcc	Select						BLANK		:	[	4.50	V]			VERIFY_L		:		4.50	V			VERIFY_H		:		5.50	V		
Read	Vcc	Select																															
BLANK		:	[	4.50	V]																												
VERIFY_L		:		4.50	V																												
VERIFY_H		:		5.50	V																												

Remarks: The range is  $-20\% \sim +20\%$  and it can be changed in 5%.

VCC voltage for COPY can not be changed.

The value is changed to the default when device code is changed and the power is turned on/off.

When mode is changed, "C" for mode change is displayed on the display panel.

(Please refer to how to read the display)

Warning: The value should not exceed the standard value of the device in the data sheet.

List of voltage selection

When COPY\_VCC=3.3V

Voltage selection (V)		
	3.90 (+20%)	
	3.75 (+15%)	
	3.60 (+10%)	VERIFY_H
	3.45 (+5%)	
COPY	3.30 (0%)	
	3.15 (-5%)	
BLANK	3.00 (-10%)	VERIFY_L
	2.85 (-15%)	
	2.70 (-20%)	

When COPY\_VCC=5V

Voltage selection (V)		
	6.00 (+20%)	
	5.75 (+15%)	
	5.50 (+10%)	VERIFY_H
	5.25 (+5%)	
COPY	5.00 (0%)	
	4.75 (-5%)	
BLANK	4.50 (-10%)	VERIFY_L
	4.25 (-15%)	
	4.00 (-20%)	

## Verify pattern - Changing the number of verify -

This is to change the check pattern of Verify.  
 [default] , [1 Time] or [2 Times] can be selected.

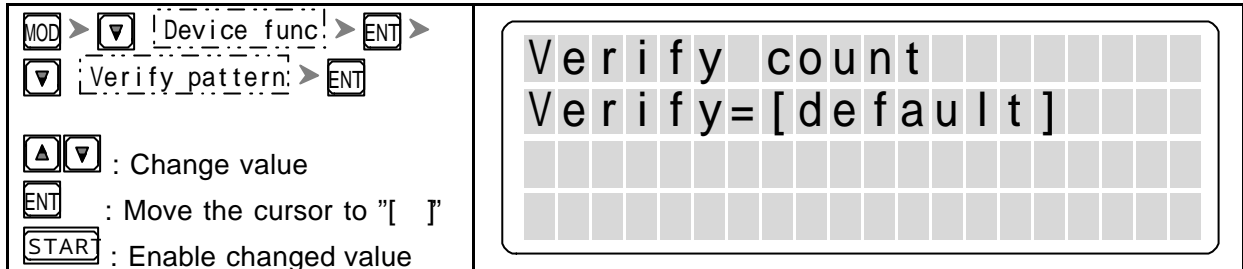

Remarks: Usually it is set as “default”

When device code is changed or the power is turned on/off, it is changed to “default”

When setting is changed, “V” for this mode is displayed.

(Please refer to how to read the display )

Device type and check pattern

Parameter	E-PROM type	EE-PROM/ FLASH type
Default	Default	Default
1 Time	VF3	VF3
2 Times	VF2 VF3	VF2 VF3

## ID Check - Setting of ID Check Function -

Usually device ID check is carried out at COPY and PROG, etc operation to avoid a mixture of different devices. This function can be turned off.

<p>MOD &gt; ▾ Device func! &gt; ENT &gt;</p> <p>▾ ID Check! &gt; ENT</p> <p>▲ ▾ : Change value</p> <p>ENT : Move the cursor to "[ ]"</p> <p>STAR : Enable changed value</p>	<div style="border: 1px solid black; padding: 5px;"> <p>Device ID Check</p> <p>ID Check = [On ]</p> </div>
---	--

Setting and the operation of M1894

Setting	Operation of M1894
ON	Device ID check is carried out (default)
OFF	Device ID check is skipped.

## Protect mode - Setting of device data protect mode -

Some FLASH memories have protected mode. When this feature is used, this mode should be changed. These devices have area to store programming data and protected information. The area for programming data is called "main memory area" and the area for protected data is called "protected area. The default is "No operat"

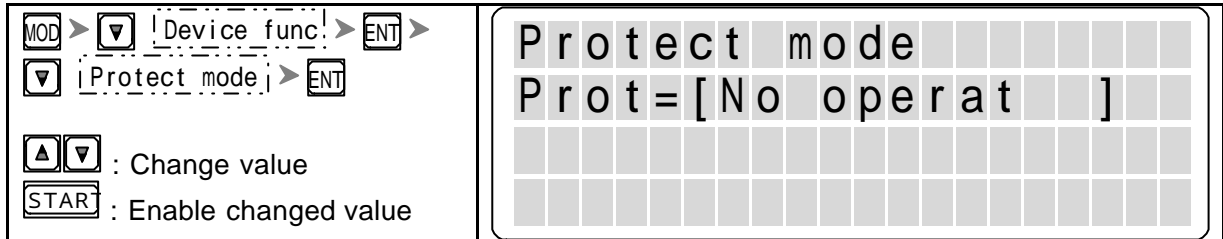

Remarks: Some supplier call protected area as "Sector-Protect" or "Block-Lock".

When device code is changed or the power is turned on/off, the setting is changed to default.

Warning: If the device currently selected does not have protect feature, LCD displays "Protect not support"  
In order to protect data, protect area must be specified.

(This chapter : Please refer to Protect Setting )

### Mode and access area

Mode	Access area	Mode display
No operat (NO OPERATION)	Only main memory area (Default)	"N"
Prot only (PROTECT ONLY)	Only protected area	"P"
Unprot/Prot (UNPROTECT/PROTECT)	Main memory、 Protected area	"U"

Remarks: A sign that indicated current mode is shown on LCD.

(Please refer to how to read display)

### Outlook of protect mode setting

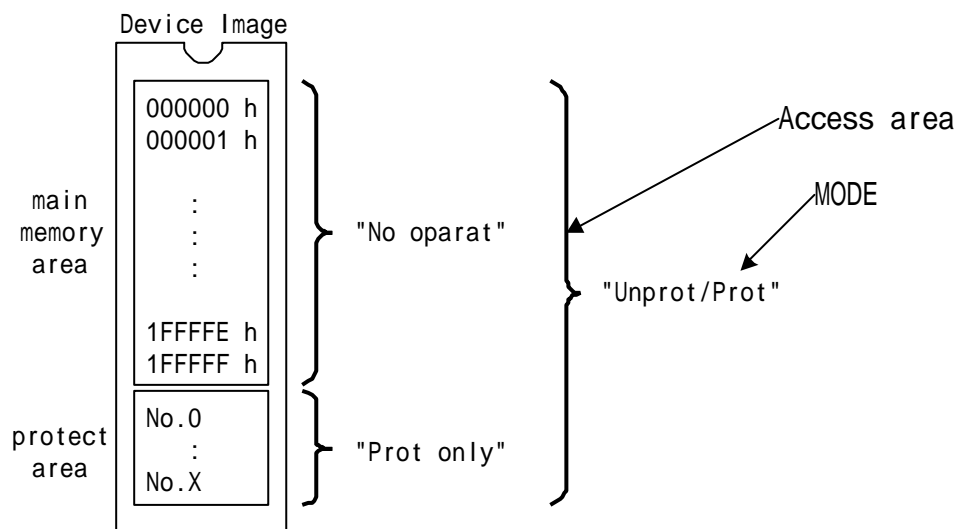

CONT operation flow chart when Unprot/Prot is set. (FLASH)

Basically the flow is the same, however timing to access to protected area in each mode is added. In case of PROG, the sequence of access is main memory protected area.

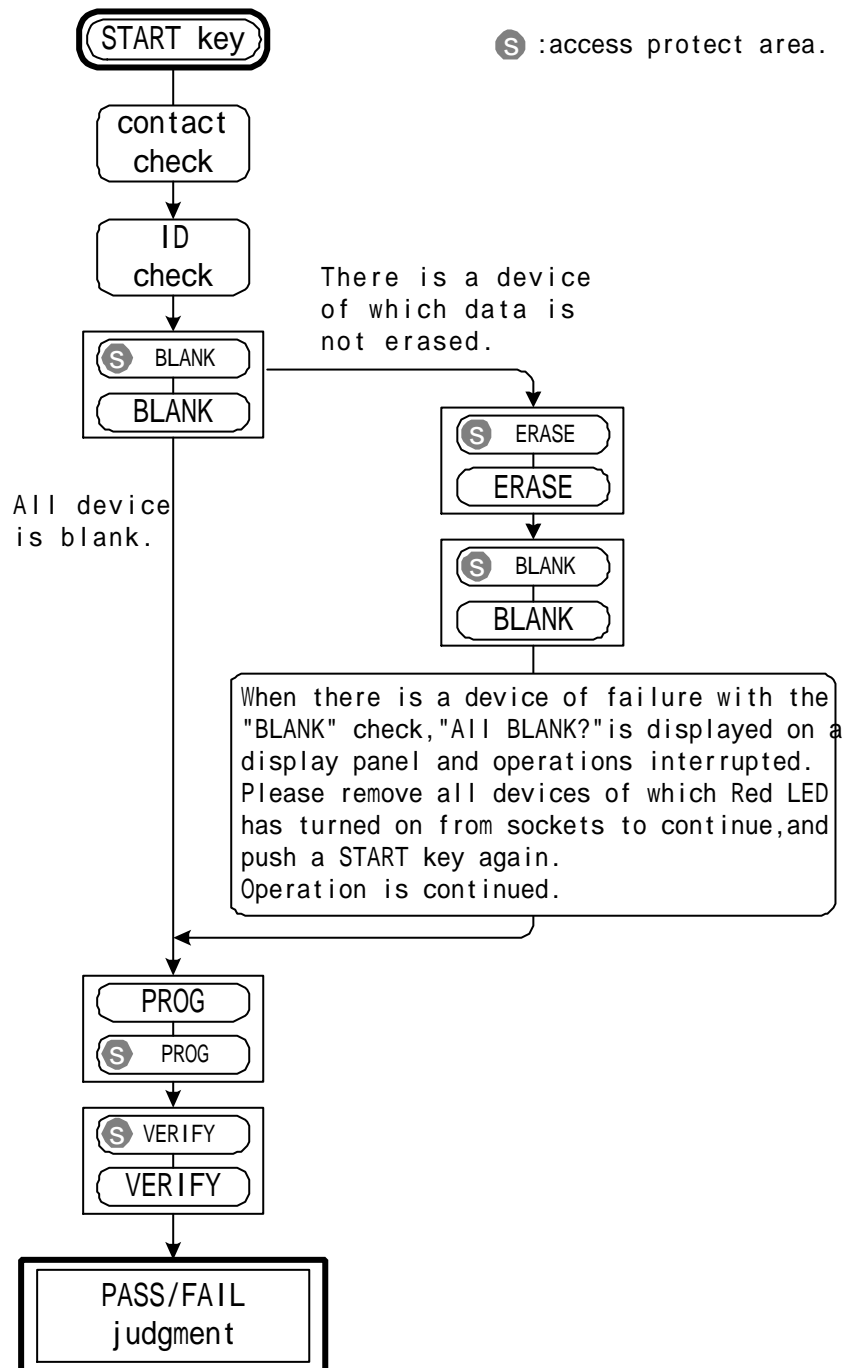

Access timing to protected area on other mode such as "COPY", "BLANK" is added. In case of PROG, it accesses to main memory first. Then goes on to protected area.

CONT operation flow chart when Prot only is set. (FLASH)

Basically the flow is the same, however access to main memory is changed to access to protected area.

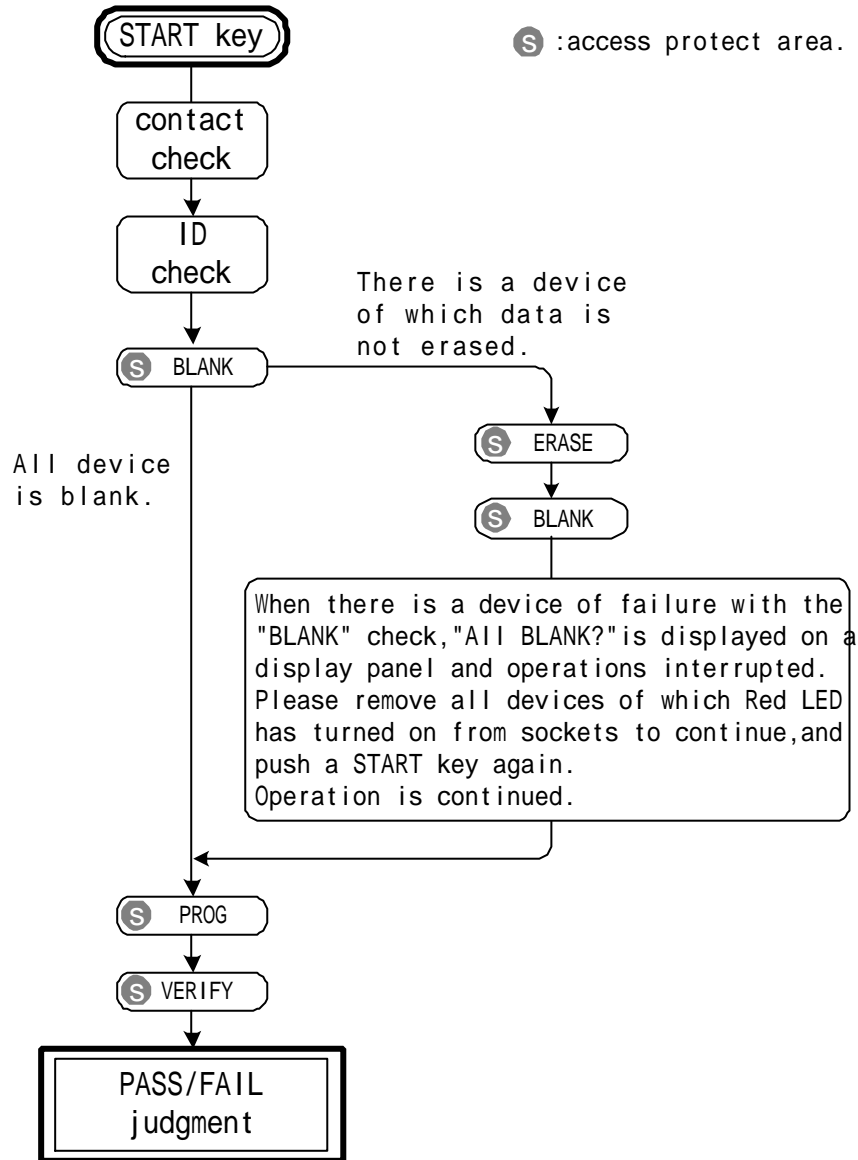

Access timing to protected area on other mode such as "COPY", "BLANK" is added.

## Protect setting - To change protect setting for protected data -

In order to apply protect on a device, not only protect mode setting but also the targeted protect area should be selected. This is called "Protect data set". The protect feature of M1894 is designed to set Protect/Unprotect of each individual area. The default setting is all "Un Protect".

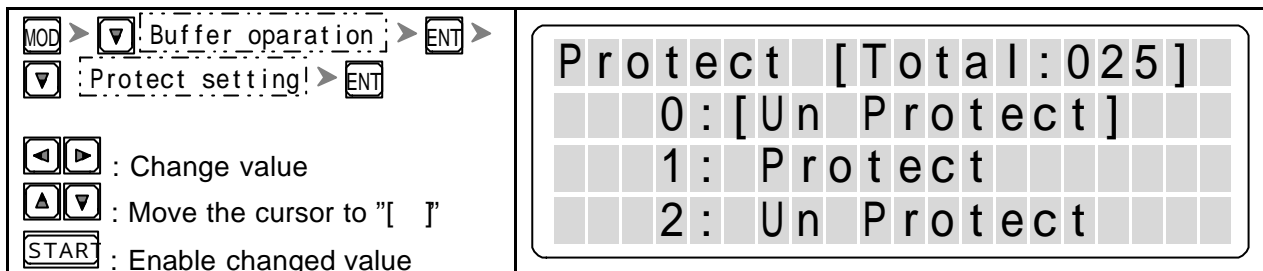

Remarks: Above display is the select screen of "AMD 32M aM29DL32x\_T". "0:", "1:", "2:" indicates the number of protect area. "0:" means "sector 0" or "block 0" in the data sheet.

"Protect" should be selected for the number to protect and "Un protect" should be selected for the number not to protect. On above screen, "TOTAL: 25" means there are 25 of protecting area. When device code is changed and the power is turned on/off, the setting is changed to default value.

Warning: The area and configuration of protect is different on each device. Please check data sheet first. Some devices do not have this feature.

If currently selected device does not support protect feature, "Protect not support!" is displayed on LCD. In order to erase protected data, "ERASE" should be executed.

## Repeat mode - Setting of repeat mode -

Repeat operation of “COPY”, “BLANK” and so forth can be set.  
 Either [off] or [Fail stop] can be selected. Usually the setting is “off”.

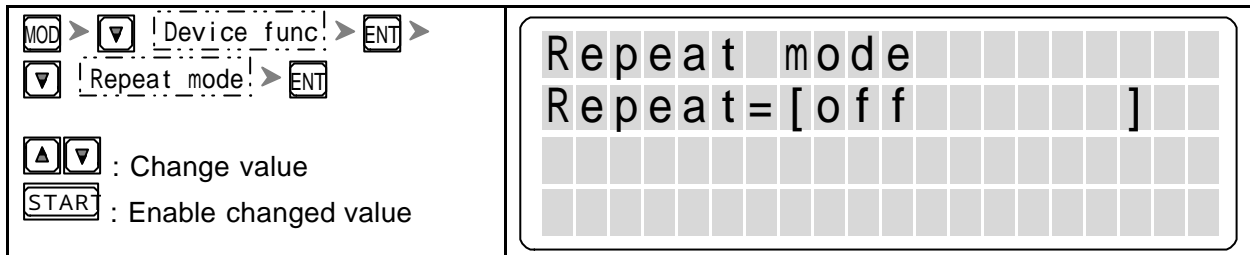

Remarks: There is no indication to indicate repeat mode.

Operation of M1894 (example: VERIFY CHECK)

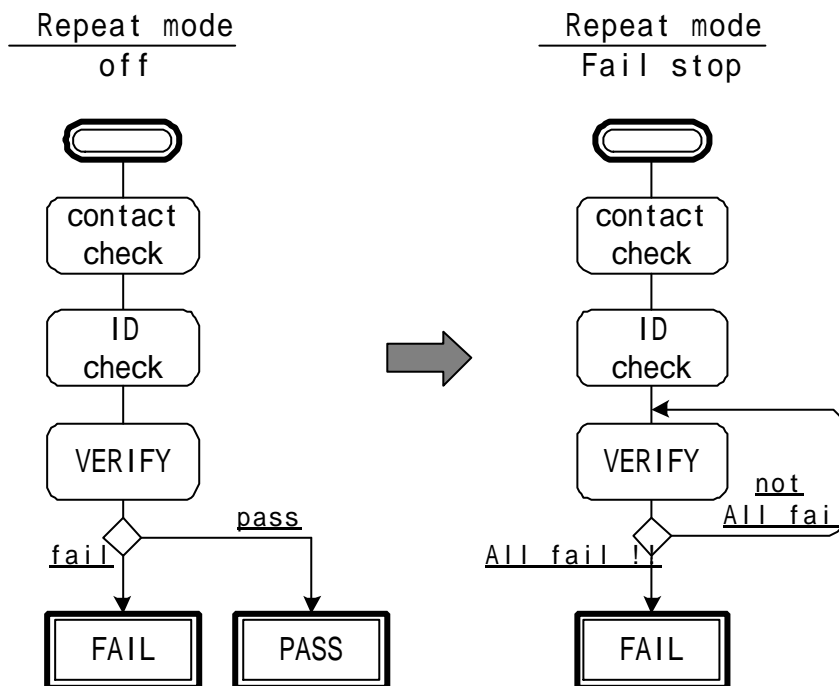

Remarks: Only very first contact check is executed.  
 When “FAIL stop” is set, all socket “FAIL” stop the operation.

## Set Prg mode - Programming different data on multiple devices -

In advance operation of M1894, there is a mode called "Set Program".

Usually the same data is programmed in the devices set on the socket. If "Set Program Mode" is applied, a memory module that consists of different devices can be programmed just by one operation.

Select set mode (Memory data length and Address size and multiplier) to set the configuration of the module. Data appropriate for the module should be stored in the buffer memory.

<p> <input type="button" value="MOD"/> &gt; <input type="button" value="v"/>   Device func.   &gt; <input type="button" value="ENT"/> &gt;  <input type="button" value="v"/>   Set Prg mode.   &gt; <input type="button" value="ENT"/> </p> <p> <input type="button" value="▲"/> <input type="button" value="▼"/> : Change value  <input type="button" value="ENT"/> : Move the cursor to "[ ]"  <input type="button" value="STAR"/> : Enable changed value         </p>	<table border="1"> <tr><td>S</td><td>e</td><td>t</td><td> </td><td>p</td><td>r</td><td>o</td><td>g</td><td>r</td><td>a</td><td>m</td><td>m</td><td>i</td><td>n</td><td>g</td><td> </td><td>m</td><td>o</td><td>d</td><td>e</td></tr> <tr><td>D</td><td>a</td><td>t</td><td>a</td><td> </td><td>b</td><td>i</td><td>t</td><td>:</td><td>[</td><td>1</td><td>6</td><td>b</td><td>i</td><td>t</td><td>]</td><td></td><td></td><td></td><td></td></tr> <tr><td>B</td><td>l</td><td>o</td><td>c</td><td>k</td><td> </td><td>:</td><td> </td><td>x</td><td> </td><td>1</td><td></td><td></td><td></td><td></td><td></td><td></td><td></td><td></td></tr> <tr><td></td><td></td><td></td><td></td><td></td><td></td><td></td><td></td><td></td><td></td><td></td><td></td><td></td><td></td><td></td><td></td><td></td><td></td><td></td></tr> </table>	S	e	t		p	r	o	g	r	a	m	m	i	n	g		m	o	d	e	D	a	t	a		b	i	t	:	[	1	6	b	i	t	]					B	l	o	c	k		:		x		1																											
S	e	t		p	r	o	g	r	a	m	m	i	n	g		m	o	d	e																																																												
D	a	t	a		b	i	t	:	[	1	6	b	i	t	]																																																																
B	l	o	c	k		:		x		1																																																																					

Remarks: This mode can not be set with "PAE mode"

When "Set Prg mode" is set, "PAE mode" is changed to default (with message )

When "PAE mode" is set "Set Prg mode" becomes invalid (without message )

Setting exceeding buffer size of M1894 can not be set.

It is operate under little endian method as the standard operation.

List of mode

Data width of Selected device	Mode (Data length of module x Blocks)
8bit	8bit x1
	8bit x2
	8bit x4
	8bit x8
	16bit x1
	16bit x2
	16bit x4
	32bit x1
	32bit x2
16bit	16bit x1N
	16bit x2N
	16bit x4N
	16bit x8N
	32bit x1N
	32bit x2N
	32bit x4N

### Set mode and the image of module (8bit-Device)

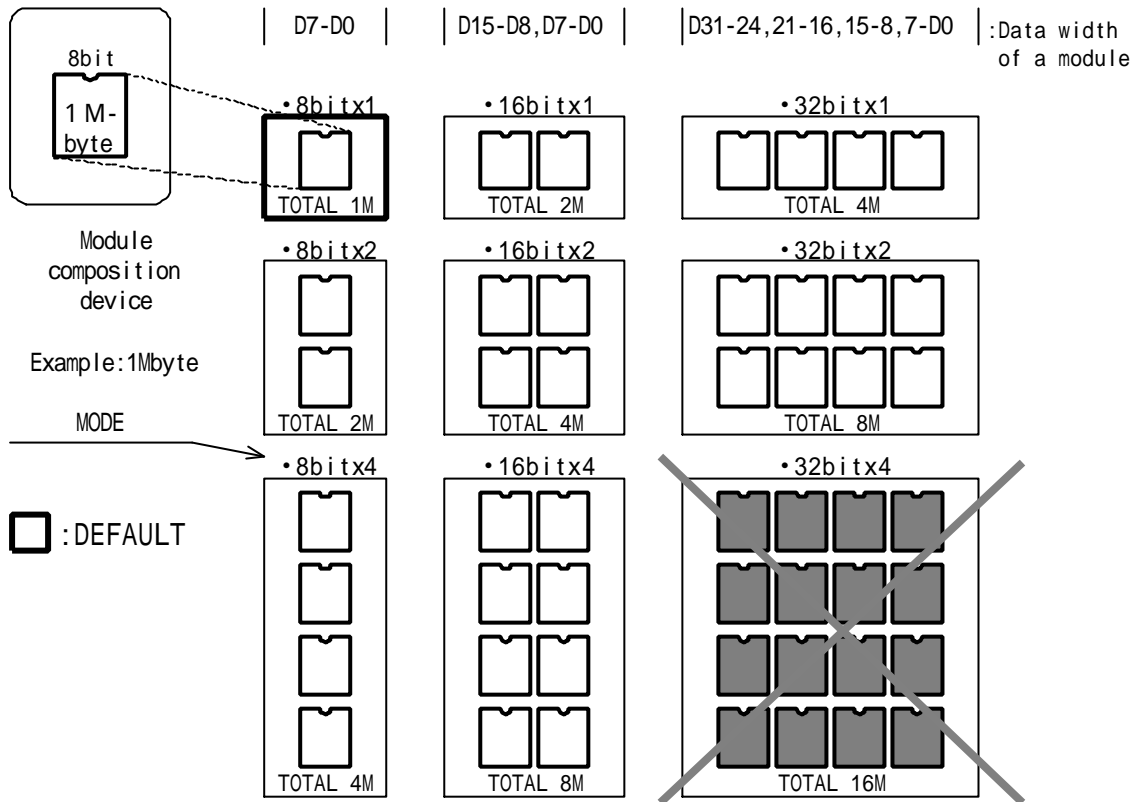

Warning: Only one type of device for the module can be selected.  
Maximum number of device to be used is 8 pieces.

Correspondence among the configuration of the module (16 bit x 2), buffer memory and position of device.

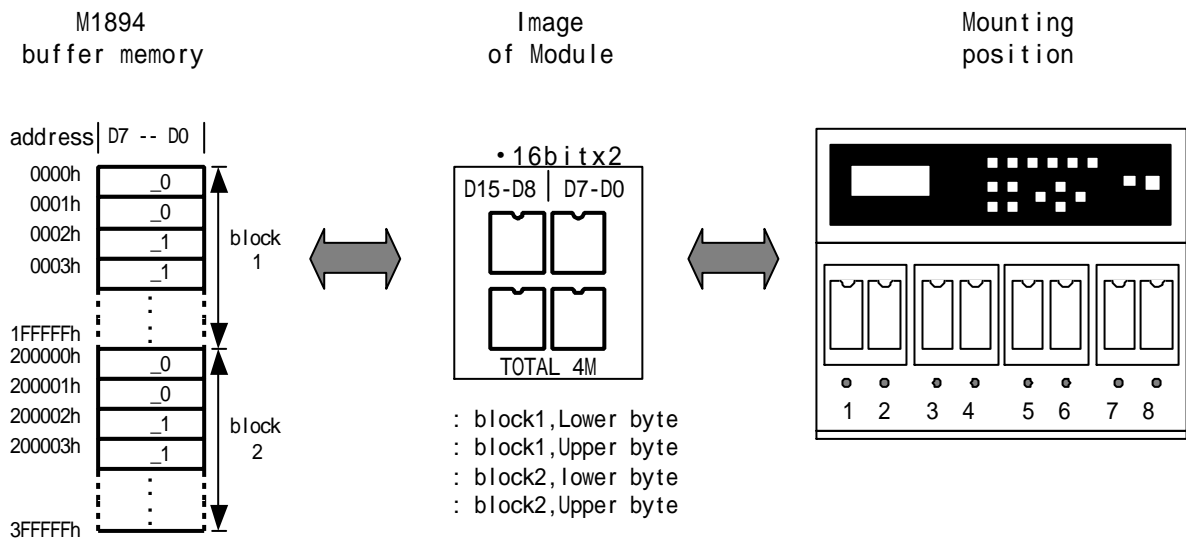

### Set mode and the configuration of the module (16bit-Device)

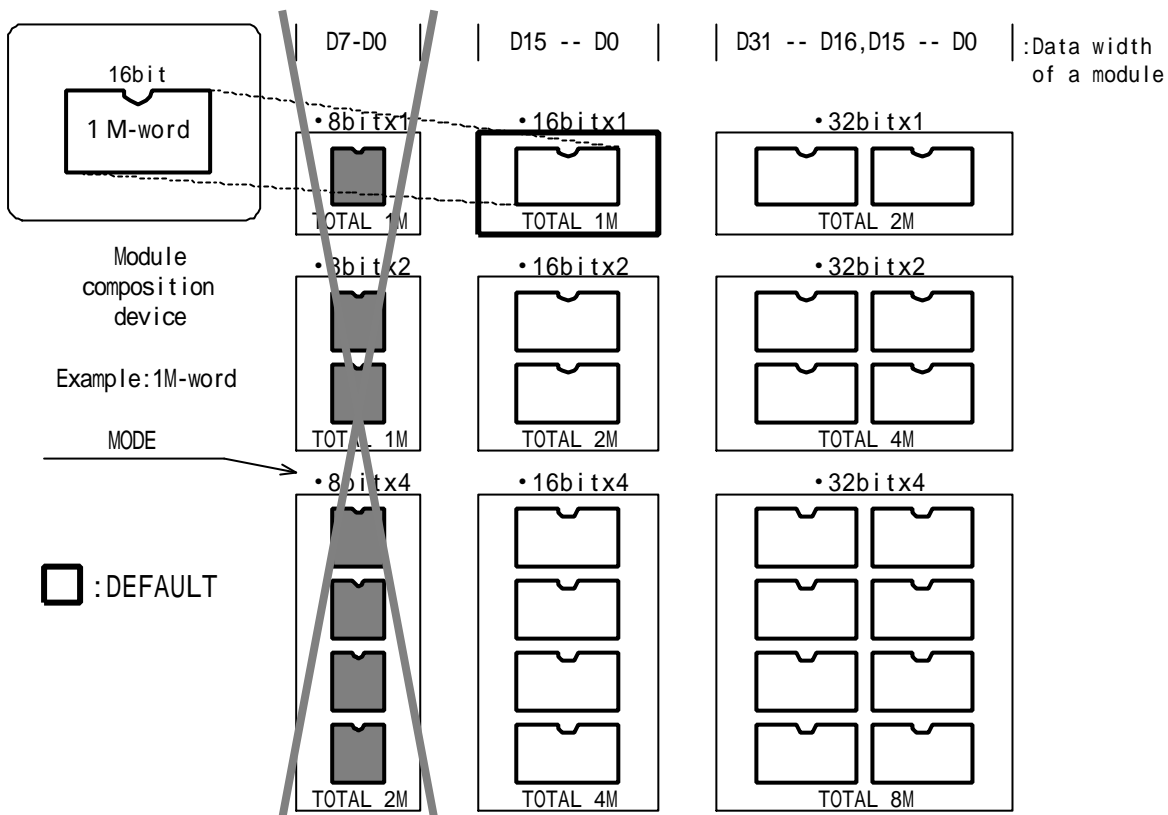

Warning: Smaller bit length of device for module can not be used.

Correspondence among the configuration of the module (16bit x2), buffer memory and position of device

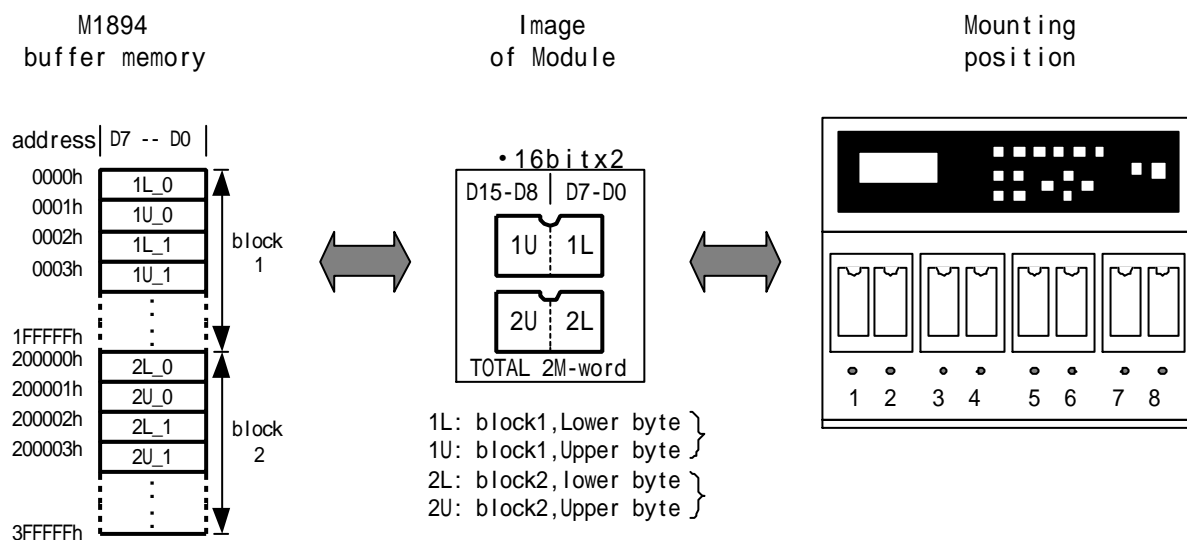

Remarks: Access under little endian mode

## COPY socket when Set program mode is selected

With standard operation, only #1 socket was valid for COPY. When “Set Prg mode” is set, you can COPY master ROM data from multiple socket according to selected mode.

COPY data is stored in each buffer memory.

### Set mode and COPY socket

Data width of Selected device	Set mode (Data width of module x Blocks)	Copy socket	Remarks
8bit	8bit x1	#1	Normal operation
	8bit x2	#1, #2	
	8bit x4	#1- #4	
	8bit x8	#1- #8	
	16bit x1	#1, #2	
	16bit x2	#1- #4	
	16bit x4	#1-#8	
	32bit x1	#1- #4	
	32bit x2	#1- #8	
16bit	16bit x1N	#1	Normal operation
	16bit x2N	#1, #2	
	16bit x4N	#1- #4	
	16bit x8N	#1- #8	
	32bit x1N	#1, #2	
	32bit x2N	#1- #4	
	32bit x4N	#1- #8	

When COPY is executed with one device.

Set program mode recognizes multiple devices as one device. For example, the following is the operation

To set “8 bit x 4” mode according to above table and execute COPY with master ROM on socket #3.

#### Contact check

As there is no device set on #1,2,4 sockets, COPY is stopped at contact check.

To continue the operation, press START once again.

#### COPY Data

Master ROM data is stored in buffer memory area of #3 socket.

Buffer memory area of #1,2,4 is **overwritten with “FFh”**

#### Results

Since 4 devices were supposed to be used, it is regarded as FAIL as a whole.

When COPY of master ROM of #3 socket is completed correctly, green light is lit on #3 LED.

Red light on #1,2,4 is lit. Other LED is not lit.

When COPY is executed with less number of devices, the same transaction is observed.

## MEMORY

Little endian mode .....	61
Buffer init (Initializing buffer memory data) .....	62
Buffer Dump/Edit (Dumping and editing buffer memory data) .....	63
Byte swap (Buffer memory data byte swap) .....	64
Word swap (Word swap of buffer memory data) .....	65
Check SUM (Calculation of add and sum) .....	66

# Memory

This is to explain the operation to change the setting of the buffer memory and memory data edit on M1894.

## Little endian mode - LITTLE ENDIAN -

Internal buffer memory of M1894 is based on a Byte (8 bit). When data that was based on byte method (8 bit) in internal buffer is used for word (16-bit) method, M1894 operates in little endian mode. Therefore, it required editing of buffer data. When you program a device using COPY data from master ROM, buffer edit is not required.

### 8bit Device

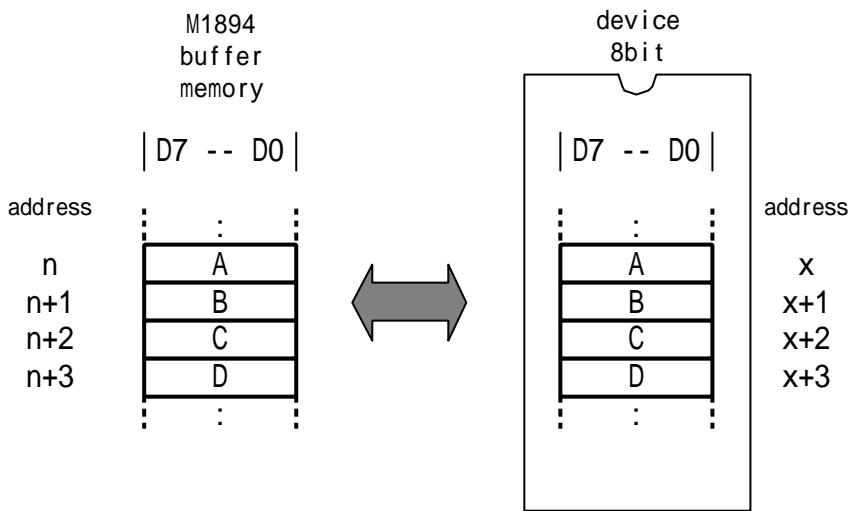

### 16bit Device

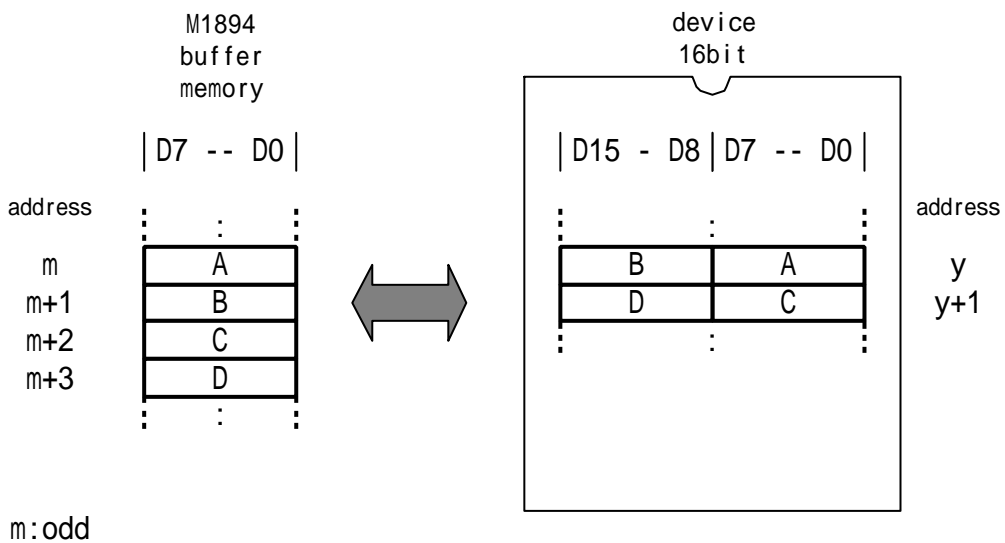

## Buffer init - Initializing buffer memory data -

This is to initialize buffer memory data.

Four pattern "All FFh", "All 00h", "03,06,0C, ...", "00,00,FF, ..." can be selected.

Regardless of device size, a certain targeted portion of buffer memory of M1894 can be initialized.

MOD > [▼] Buffer operation > [ENT] >

[▼] Buffer init > [ENT]

[▲][▼] : Change value

[◀][▶] : Move digits

[ENT] : Move the cursor to "[ ]"

[STAR] : Execute initialization

```

Buffer Initialize
start:[0000000]
end   : 1FFFFFF
Ptrn  : All FFh
                    
```

Pattern and initializing data

Pattern	Data (hex)
All FFh	"FF"
All 00h	"00"
03, 06, 0C, ...	"03", "06", "0C", "18", "30", "60", "C0", ... Repeat
00, 00, FF, ...	"00", "00", "FF", "FF", "00", "00", "FF", ... Repeat

## Buffer Dump/Edit - Dumping and editing buffer memory data -

This is a feature to check and edit the contents of the buffer memory data.

Dumping ( Dump )

MOD > Buffer operation > ENT >

Buffer DUMP/EDIT > ENT

◀ ▶ : Change digit

▲ ▼ : Change address

ADDRESS	0000000	DUMP			
0000000	FF	FF	FF	FF	
0000004	FF	FF	FF	FF	
0000008	FF	FF	FF	FF	

COM : editor mode / change dump mode

Change data ( Edit )

◀ ▶ : Change digit

▲ ▼ : Change data

Remarks: When up/down key is pressed, data is renewed with a message.

ADDRESS	0000000	EDIT			
0000000	[FF]	FF	FF	FF	
0000004	FF	FF	FF	FF	
0000008	FF	FF	FF	FF	

# Byte swap

# - Buffer memory data byte swap -

Swapping buffer memory data per byte.  
Swapping whole buffer memory area.

MOD > ▾ Buffer operation > ENT >  
▾ Byte swap > ENT

STAR : Execute byte swap

Byte swap  
OK -> [START] key

Byte swap  
Running...

Remarks: When it is completed, the display is changed to initial screen.  
Check data with " BUFFER DUMP/EDIT" function.

Operation: MOD > ▾ Buffer operation > ENT > ▾ Buffer DUMP/EDIT > ENT

## •Byte Swap Image

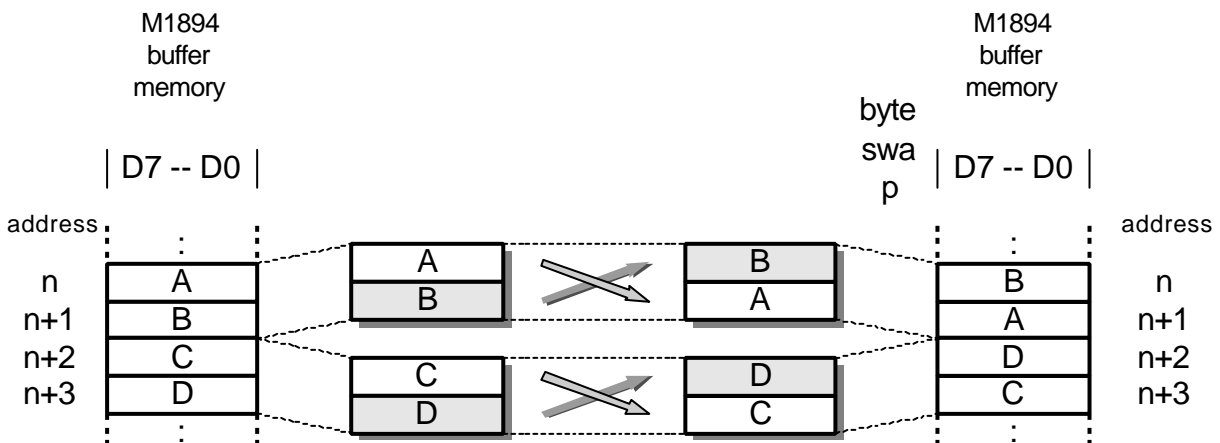

n:odd

## Word swap

## - Buffer memory data word swap -

Swapping buffer memory data per word.

Swapping whole buffer memory area.

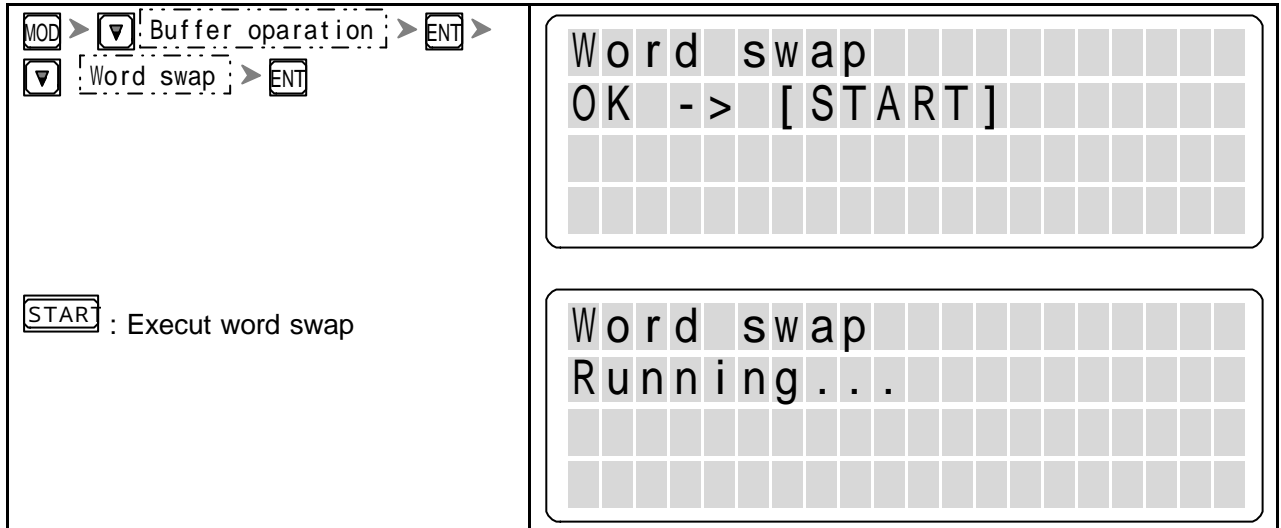

Remarks: When it is completed, the display is changed to initial screen.

Check data with "BUFFER DUMP/EDIT" function.

Operation: **MOD** > **▼** **Buffer operation** > **ENT** > **▼** **Buffer DUMP/EDIT** > **ENT**

### Word Swap Image

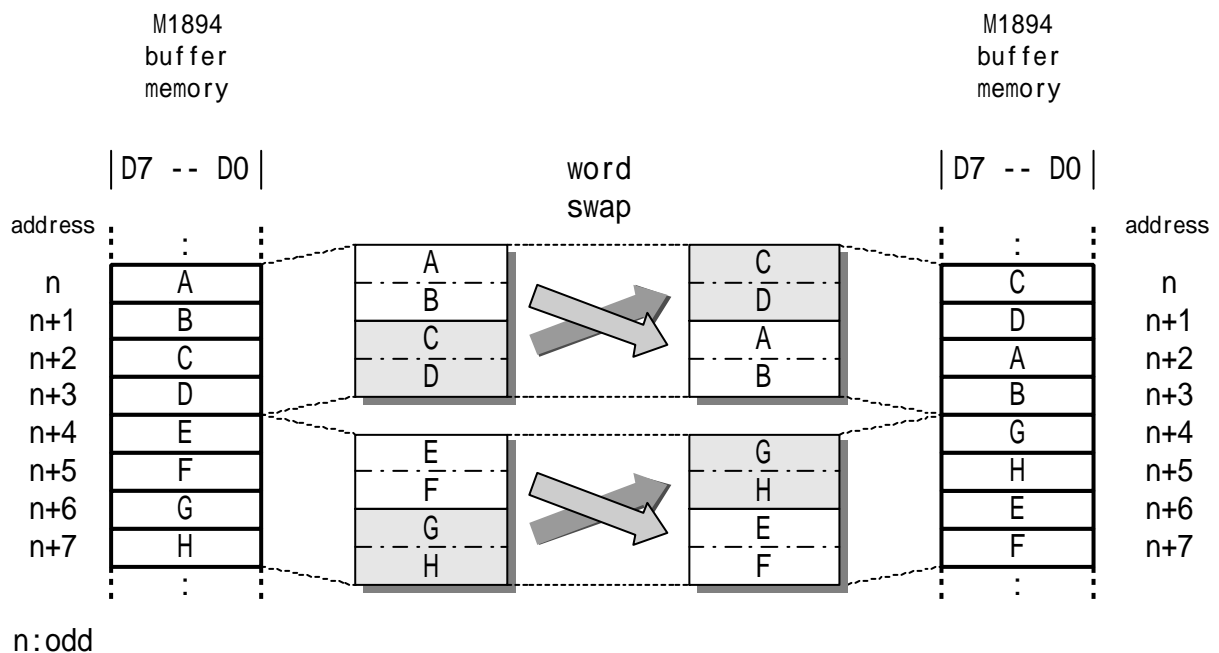

## Check SUM - Calculation of add and sum -

To calculate the operating buffer memory data of the targeted device in add and sum at byte (8bit).

MOD > ▼ Buffer operation > ENT >  
▼ Check sum > ENT

```

Check sum calc.
OK -> [START] key
Start adr=0000000
End   adr=03FFFFFF
    
```

```

Check sum calc.
Calucurating...
Start adr=0000000
End   adr=03FFFFFF
    
```

```

Check sum calc.
Socket 1
SUM:006CE0D
XOR:C3
    
```

STAR : Execute calculation

Applicable buffer address of the operating buffer memory to be calculated is displayed. Press start after confirming the value for the targeted area.

Displaying results.

▲▼ : Check SUM of each socket is displayed.

Warning: SUM,XOR is calculated in byte (8 bit).

“PAE” setting is valid.

Please set device code before executing check SUM as the buffer address calculation area is different depending on the data length of the device.

Data length and calculation area of buffer address

Example) “PAE” setting (0000, 1FFF, 500)

Initialize pattern: in case (0000, 1FFFFFFF, pattern FF)

Device data length	Address calculation area (hex)	result of check SUM (hex)
8 bit	500 ~ 24FF	001FE000, 00
16 bit	500 ~ 44FF	003FC000, 00

Example of calculation

Data line (hex)	SUM calculation (hex)	XOR calculation (hex)
1 <sup>st</sup> : AA	= AA	= AA
2 <sup>nd</sup> : 55	[AA] + 55 = FF	[AA] ^ 55 = FF
3 <sup>rd</sup> : AA	[ FF ] + AA = 1A9	[ FF ] ^ AA = 55

# SYSTEM

- Device Check / Buzzer / LED .....68
- Checking the firmware version of M1894 .....69
- Updating the firmware version of M1894 .....70

## Device Check / Buzzer / LED

### Device Check mode

In order to avoid wrong insertion in the socket or device failure, device check (contact check) function is provided in M1894. However, device check could not work on some microcomputers with memory due to its complicity. When this kind of device is used, device check can be set as OFF. When it is turned OFF, each mode is automatically executed by pressing START. Please make sure that the direction of the device on the socket is correct. Otherwise, it may damage the device.

### Buzzer mode

M1894 has a feature to let you know the send of an operation with a buzzer. Usually it is set as ON. When it is not required, please turn it OFF.

### LED mode

M1894 has a feature to let you know the result of operation with LED light. Usually the socket without device (Empty Socket) is indicated with red LED. When this mode is OFF, LED is not lit for empty sockets.

The screenshot shows the navigation path: MOD > System config > Devchk/BZ/LED. The settings are as follows:

Devchk/BZ/LED	Devchk/BZ/LED	settin
Buzzer mode	= [ On ]	
Device check	= On	
Empty LED	= On	

Legend for navigation keys:

- ▲ ▼ : Change value
- ENT : Move the cursor to "[ ]"
- STAR : Enable changed value

Remarks: By pressing START key, the screen is turned to initial display with renewed setting.

Warning: When device code and the power is turned on/off, these settings are changed to default.

Mode	Setting
Buzzer mode	When the power is turned "ON"
Device check	When device code is changed and the power is turned "ON"
Empty LED	When the power is turned "ON"

## Checking the firmware version of M1894

The firmware version of M1894 can be checked.

Model name (M1894), version, release date, installed memory are displayed.

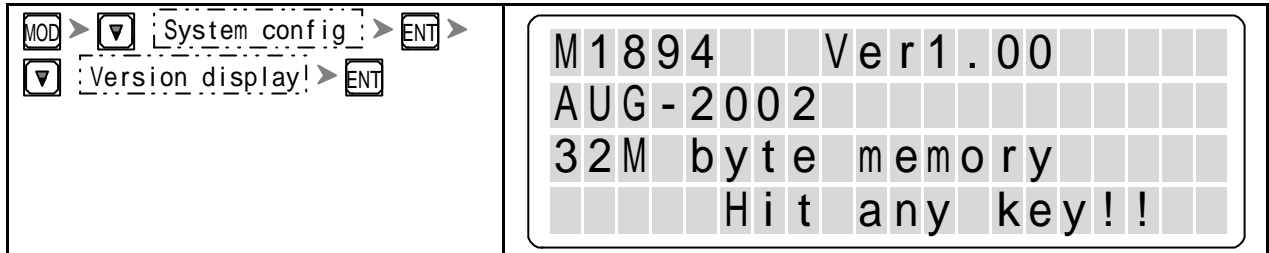

## Updating the firmware of M1894

This is to use to make an update of the firmware versions, in order to add new device algorithm which is newly supported.

Before UPDAE is executed, the memory must be initialized. Version up data load is required.

### Preoperation

1. Initialize the buffer memory of M1894 with "all FFh".
2. Load data for version up in the buffer memory (from 0000)

The screenshot shows the M1894 device interface. On the left, the navigation menu is visible with 'System config' selected and 'System update' highlighted. Below the menu, a 'STAR' button is labeled ': Execute updating'. On the right, the display shows the following text:

```
Update system
New Update
OK -> START
NO -> RESET
```

Below this, a warning message is displayed:

```
* Now update system
!! Don't touch
any key !!
```

When version up data is not available, "key\_code error" is displayed.

After displaying above message, LED starts to blink.

As the process goes forward, LED is turned to green.

When all LED is turned to green, the version up is completed (the message on the display is unchanged).

When the update is completed, M1894 automatically restart and execute self-check. After the self-check, confirm the version is updated.

**Warning:** When this operation is failed, M1894 does not work at all. For the update, please consult with Minato authorized distributor in your area.

## DATA TRANSFER

<b>Data Transfer</b> .....	72
RS Config (Setting interface configuration) .....	73
Data Format (Setting transfer data format) .....	74
Serial In (Data transfer: serial input) .....	75
Serial Out (Data transfer: serial output) .....	76
Protect SR In (Protected data transfer: serial input) .....	77
Protect SR Out (Protected data transfer: serial output) .....	78
<b>Remote control</b> .....	79
IF Select (Slection of an Interface) .....	80
Remote Config (Setting the condition of remote mode) .....	81
Executing remote mode .....	83

## Data Transfer

M1894 is equipped with RS-232C serial interface to communicate with external device. When data is transferred from PC to the buffer memory through RS-232C, the remote control can be accomplished via command data. This is to explain data transfer.

Transferring command data                      (This chapter: Please refer to remote control)

To use these communication functions, the condition of the transfer must be preset.

## RS Config - Setting interface configuration -

How to set RS232C

When communicating with other device through RS232C, match the communication setting with the targeted device.

RS232C to connect with PC should be straight cable that is available in the market.

MOD > System config > ENT >  
RS config > ENT

▲▼ : Change value  
ENT : Move the cursor to "[ ]"  
STAR : Enable changed value

Serial Config

BAUD RATE [19200 ]

PARITY None

CHARACTER 8bit

Serial Config

CHARACTER 8bit

STOP BIT 2bit

CONTROL [None ]

When START key is pressed, the display is changed to the initial screen with renewed setting.

Items for setting and parameters to be set

Items for setting	Parameters
Baud rate	9600, 19200, 38400, 57600, 115200 [bps]
Parity	None, ODD, EVEN
Character	7, 8 [bit]
Stop Bit	1, 2 [bit]
Controlle	None, Xon / Off, Rts / Cts

Remarks: This setting is valid even if the power is turned off.

When the firmware version is updated, it should be set once again.

## Data Format - Setting transfer data format -

When data is transferred, not only the communication setting but also transfer data format must be set. Usually data format of data file must be set.

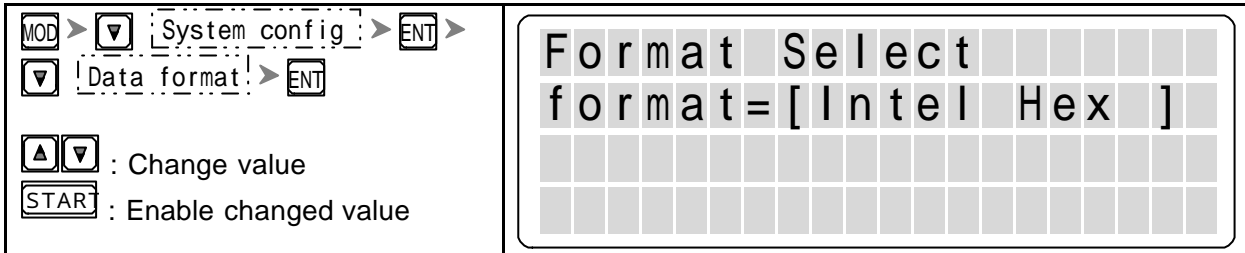

When START key is pressed, the display is changed to the initial screen with renewed setting.

Format to be selected and specification

Format name	Data format	SUM	Address	End record
Minato Hex	ASCII	None	Including	Including
Intel Hex	ASCII	Including	Including	Including
Motorola S	ASCII	Including	Including	Including
HP64000ABS	Bin	Including	Including	Including
No Format	Bin	None	None	None

Remarks: This setting is valid even if the power is turned off.

When the firmware version is updated, it should be set once again.

## Serial In - Data transfer : Serial input -

Serial I/F of M1894 become ready to receive. When data is received, it is stored in the buffer memory according to the transfer data format that was preset.

Start address in transfer data format can be specified. (Other data is ignored)

Store start address of the buffer memory can be specified.

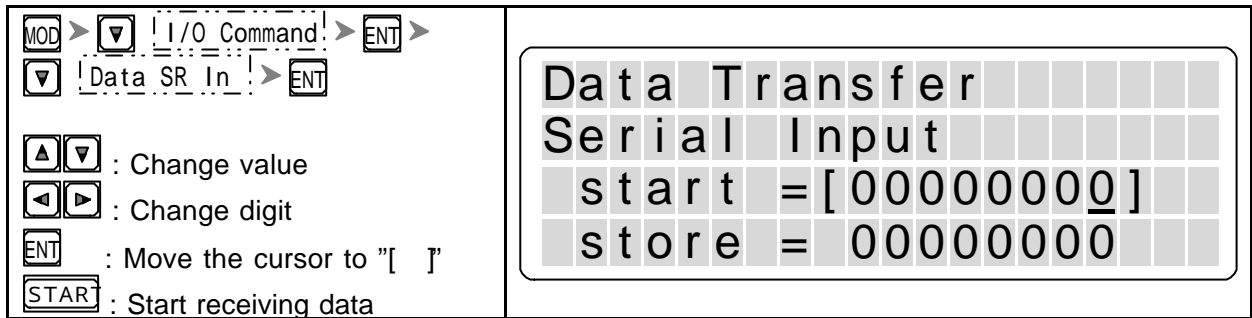

### Serial In Image

setting:  
Data Start Address = 2400h  
Buffer Store Address = 1000h

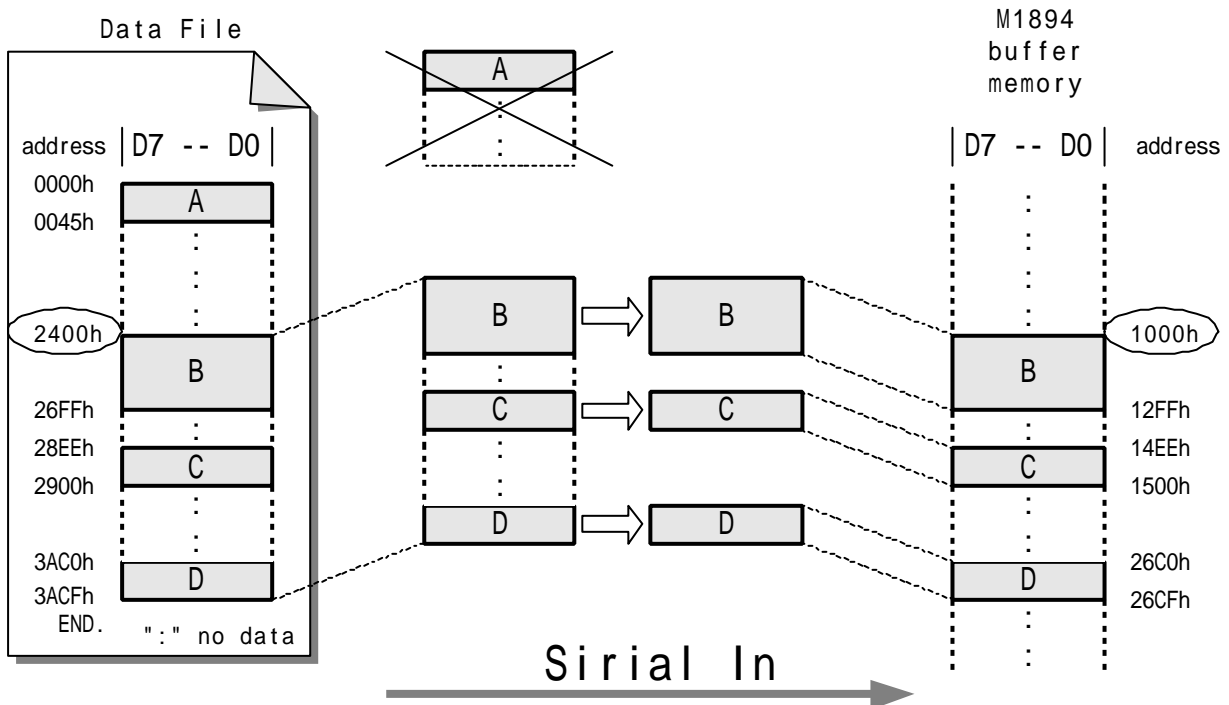

When transfer is completed, \*\*\* COMPLETE \*\*\*\* is displayed.

## Serial Out - Data transfer : Serial output -

The data in the buffer memory of M1894 is transferred to external device through serial interface.  
 The buffer data is converted and output according to the initial format setting.  
 Store start address of the buffer memory can be specified.

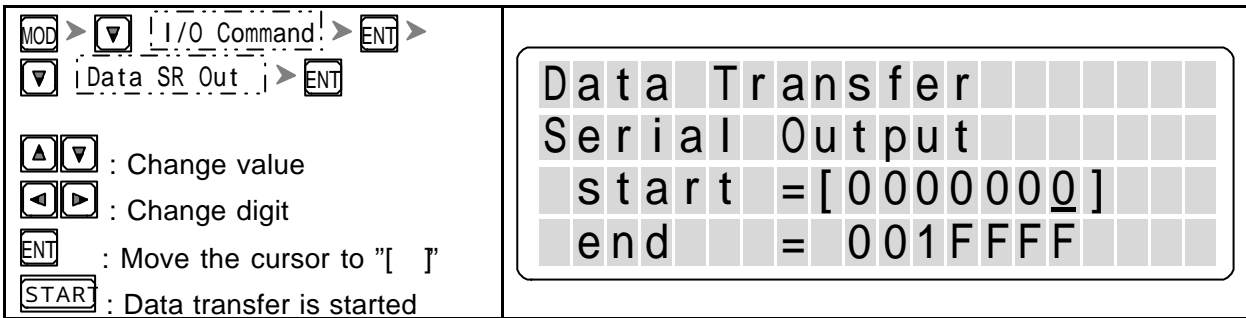

### Serial Out Image

setting:  
 Buffer Start Address = 1000h  
 Buffer End Address = 1FFFh

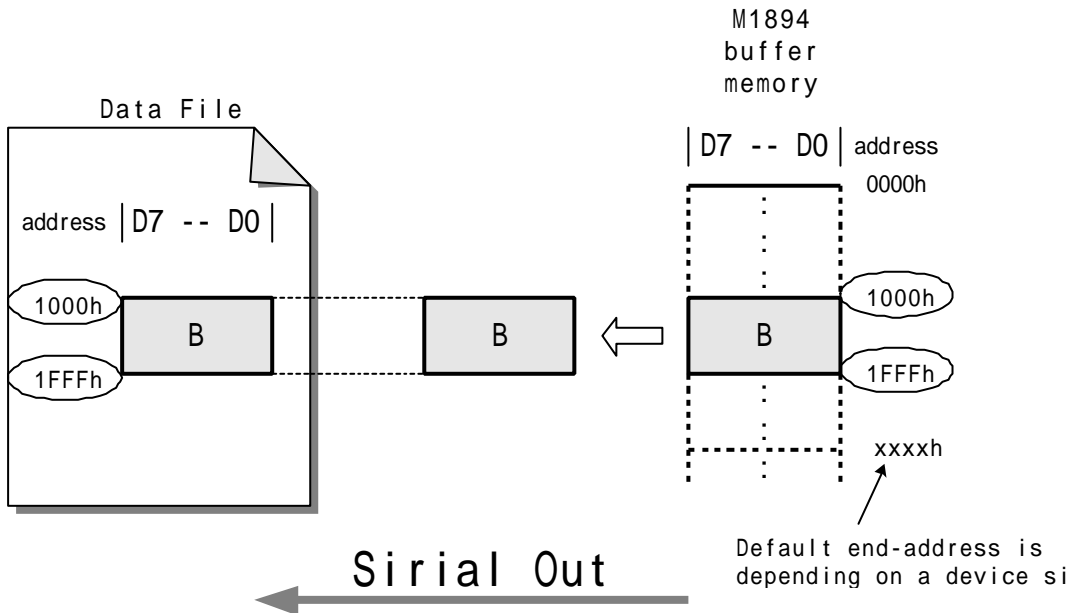

When transfer is completed, \*\*\* COMPLETE \*\*\* is displayed.

## Protect SR In - Protected data transfer : Serial Input -

“Protected data” is read in M1894 through serial interface.

The serial interface of M1894 becomes ready to receive. After that, received data is stored in the register for sector information according to the format that is currently set.

Format data start address (protected area start number: hex) can be specified.

If currently selected device does not support this feature, protect function can not be applied.

<p>MOD &gt; ▼ I/O Command &gt; ENT &gt;</p> <p>▼ Protect SR In &gt; ENT</p> <p>▲ ▼ : Change value</p> <p>◀ ▶ : Change digit</p> <p>STAR : Start receiving data</p>	<table border="1"> <tr><td>P</td><td>r</td><td>o</td><td>t</td><td>e</td><td>c</td><td>t</td><td> </td><td>T</td><td>r</td><td>a</td><td>n</td><td>s</td><td>f</td><td>e</td><td>r</td><td> </td><td> </td><td> </td><td> </td><td> </td></tr> <tr><td>S</td><td>e</td><td>r</td><td>i</td><td>a</td><td>l</td><td> </td><td>I</td><td>n</td><td>p</td><td>u</td><td>t</td><td> </td><td> </td><td> </td><td> </td><td> </td><td> </td><td> </td><td> </td><td> </td></tr> <tr><td>P</td><td>_</td><td>s</td><td>t</td><td>a</td><td>r</td><td>t</td><td> </td><td>=</td><td>[</td><td>0</td><td>0</td><td>0</td><td>0</td><td>0</td><td>0</td><td>0</td><td>0</td><td>]</td><td> </td><td> </td></tr> <tr><td> </td><td> </td><td> </td><td> </td><td> </td><td> </td><td> </td><td> </td><td> </td><td> </td><td> </td><td> </td><td> </td><td> </td><td> </td><td> </td><td> </td><td> </td><td> </td><td> </td><td> </td></tr> </table>	P	r	o	t	e	c	t		T	r	a	n	s	f	e	r						S	e	r	i	a	l		I	n	p	u	t										P	_	s	t	a	r	t		=	[	0	0	0	0	0	0	0	0	]																							
P	r	o	t	e	c	t		T	r	a	n	s	f	e	r																																																																						
S	e	r	i	a	l		I	n	p	u	t																																																																										
P	_	s	t	a	r	t		=	[	0	0	0	0	0	0	0	0	]																																																																			

When transfer is completed, \*\*\* COMPLETE \*\*\*\* is displayed.

## Protect SR Out - Protected data transfer : Serial output -

“Protected data” is outputted to external device through serial interface. The protected data is converted to the format that is currently set.

Parameter can not be changed. If currently selected device does not support this feature, protect function can not be applied.

The screenshot shows a menu structure where 'I/O Command' is selected, and 'Protect SR Out' is the active option. The main display area shows the following text:

```

Protect Transfer
Serial Input
P_start = 0000000
P_end   = 0000018
    
```

Below the menu, a 'STAR' button is visible with the text: Data transfer is started

Parameter	Value (hex)
P_start	The start number of protected area (0)
P_end	The end number of protected area (It is different in each type of device)

Remarks: Parameter can not be changed.

Above message is the display screen to select “AMD 32M Am29DL32X\*T”.

Above device have 25 protect area (number 0 – 24 dec)

Parameter	Number (dec)	Number (hex)
P_start	0	00
P_end	24	18

When transfer is completed, \*\*\* COMPLETE \*\*\*\* is displayed.

## Remote control

In addition to the key switch operation that has been described in former pages, M1894 can be operated by remote control by directly sending command from an external machine to M1894 through serial interface. Minato called it "Remote Control Mode of M1894" or "Remote Mode).

In order to use the feature of remote control, not only the condition of serial interface communication setting but also the condition of command transfer method must be set.

Serial interface communication setting      (Communication function: Please refer to "Rs config")

This is to explain the setting on the panel operation and execution method.

## IF Select - Selection of interface -

This is to select interface for the communication with other products.  
RS-232C and USB can be selected. Default for shipment is RS-232C.

<p>MOD &gt; [▼] Remote mode &gt; [ENT] &gt; [▼] IF select &gt; [ENT]</p> <p>[▲] [▼] : Change value [STAR] : Enable changed value</p>	<table border="1"><tr><td>I</td><td>n</td><td>t</td><td>e</td><td>r</td><td>f</td><td>a</td><td>c</td><td>e</td><td> </td><td>s</td><td>e</td><td>l</td><td>e</td><td>c</td><td>t</td><td> </td><td> </td><td> </td><td> </td></tr><tr><td>I</td><td>n</td><td>t</td><td>e</td><td>r</td><td>f</td><td>a</td><td>c</td><td>e</td><td>=</td><td>[</td><td>R</td><td>S</td><td>-</td><td>2</td><td>3</td><td>2</td><td>C</td><td> </td><td>]</td></tr><tr><td> </td><td> </td><td> </td><td> </td><td> </td><td> </td><td> </td><td> </td><td> </td><td> </td><td> </td><td> </td><td> </td><td> </td><td> </td><td> </td><td> </td><td> </td><td> </td></tr><tr><td> </td><td> </td><td> </td><td> </td><td> </td><td> </td><td> </td><td> </td><td> </td><td> </td><td> </td><td> </td><td> </td><td> </td><td> </td><td> </td><td> </td><td> </td><td> </td></tr></table>	I	n	t	e	r	f	a	c	e		s	e	l	e	c	t					I	n	t	e	r	f	a	c	e	=	[	R	S	-	2	3	2	C		]																																						
I	n	t	e	r	f	a	c	e		s	e	l	e	c	t																																																																
I	n	t	e	r	f	a	c	e	=	[	R	S	-	2	3	2	C		]																																																												

Remarks: To use USB, USB driver must be installed in the PC. Please refer to the M1894 USB driver install guide for the installation.

## Remote config - Setting of the condition of remote mode -

The condition of remote mode is specified. ECHO, PROMPT, ACK/NAK, BZ-mode can be set.

<p> <input type="checkbox"/> MOD &gt; <input type="checkbox"/> Remote mode! &gt; <input type="checkbox"/> ENT &gt;  <input type="checkbox"/> Remote config &gt; <input type="checkbox"/> ENT         </p> <p> <input type="button" value="▲"/> <input type="button" value="▼"/> : Change value  <input type="button" value="ENT"/> : Move the cursor to "[ ]"  <input type="button" value="STAR"/> : Enable changed value         </p>	<table border="1"> <tr><td>Remote Config</td><td></td><td></td><td></td><td></td><td></td><td></td><td></td><td></td><td></td></tr> <tr><td>ECHO</td><td></td><td></td><td>[</td><td>ON</td><td></td><td></td><td></td><td>]</td><td></td></tr> <tr><td>PROMPT</td><td></td><td></td><td>#</td><td></td><td></td><td></td><td></td><td></td><td></td></tr> <tr><td>ACK/NAK</td><td></td><td></td><td>OFF</td><td></td><td></td><td></td><td></td><td></td><td></td></tr> </table> <table border="1"> <tr><td>Remote Config</td><td></td><td></td><td></td><td></td><td></td><td></td><td></td><td></td><td></td></tr> <tr><td>PROMPT</td><td></td><td></td><td>#</td><td></td><td></td><td></td><td></td><td></td><td></td></tr> <tr><td>ACK/NAK</td><td></td><td></td><td>OFF</td><td></td><td></td><td></td><td></td><td></td><td></td></tr> <tr><td>BZ MODE</td><td></td><td></td><td>[</td><td>ON</td><td></td><td></td><td></td><td>]</td><td></td></tr> </table>	Remote Config										ECHO			[	ON				]		PROMPT			#							ACK/NAK			OFF							Remote Config										PROMPT			#							ACK/NAK			OFF							BZ MODE			[	ON				]	
Remote Config																																																																																	
ECHO			[	ON				]																																																																									
PROMPT			#																																																																														
ACK/NAK			OFF																																																																														
Remote Config																																																																																	
PROMPT			#																																																																														
ACK/NAK			OFF																																																																														
BZ MODE			[	ON				]																																																																									

### Explanation of parameter

#### “ECHO” (ECHO-bsak)

This is to select whether code that is sent from external machine is returned to external machine or not. Some special codes are ignored and are not effective for Echo back even if “ECHO on” is set.

#### “PROMPT”

The character for “READY status” that indicates the end of a process of M1894 to external machine can be selected.

#### “ACK/NAK” (ACKnowledge / Negative-AcKnowledge)

M1894 has a function to send ACK when data from external machine is received correctly and to send NAK when error is detected in data that is transferred from external machine and to send NAK. You can select whether you use this function or not.

ACK : ‘A’ (41h)

NAK : ‘N’ (4Eh)

#### “BZ mode” (Buzzer mode)

You can set a beep sound indicating finishing of each process. You can select whether you use this function or not.

There are a few settings of which parameters are fixed.

#### “TIME OUT”

At data input mode, TIME OUT function let the process stop if input is not observed through interface for certain period of time.

#### “DUMMY READ”

This function is to skip reading received format data after end record is received. In case of M1894, it is fixed as “ON”.

Items to be selected and parameters

Items	Parameters
ECHO	ON, OFF
PROMPT	#, # <b>CR</b> <b>LF</b> , none
ACK / NAK	ON, OFF
BZ mode	ON, OFF

The following code in remote mode input command is treated as special code. Even with echo back is on, straightforward enco back can not be processed.

Character		Process of M1894	Character		Process of M1894
code	Hex		code	Hex	
NUL	00	-	DLE	10	-
SOH	01	-	<b>DC1</b>	<b>11</b>	<b>XON</b>
STX	02	-	DC2	12	-
ETX	03	-	<b>DC3</b>	<b>13</b>	<b>XOFF</b>
<b>EOT</b>	<b>04</b>	<b>Cancel</b>	DC4	14	-
ENQ	05	-	NAK	15	-
ACK	06	-	SYN	16	-
BEL	07	-	ETB	17	-
<b>BS</b>	<b>08</b>	<b>Back space</b>	CAN	18	-
HT	09	-	EM	19	-
LF	0A	-	SUB	1A	-
VT	0B	-	ESC	1B	-
FF	0C	-	FS	1C	-
<b>CR</b>	<b>0D</b>	<b>Command terminator</b>	GS	1D	-
SO	0E	-	RS	1E	-
SI	0F	-	US	1F	-
			<b>DEL</b>	<b>7F</b>	<b>Back space</b>

- : Ignored

## Execution of Remote mode

### Executing panel operation in remote mode

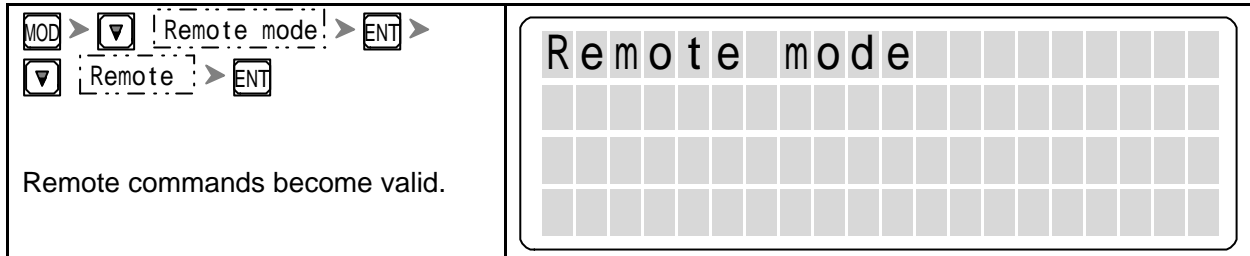

### Execut remote mode from external machine

This is to input remote code from external machine that is connected with serial interface. When M1894 received remote code, the above message is displayed and send prompt # to external terminal.

Key board operation : Ctrl+E Ctrl+E  
 ASCII (hex) : ENQ(05h) ENQ(05h)

Warning: Remote command can be received only when the initial display is shown.  
 When it does not work, press reset key and input remote code once again.

#### Outline of the execution of remote mode

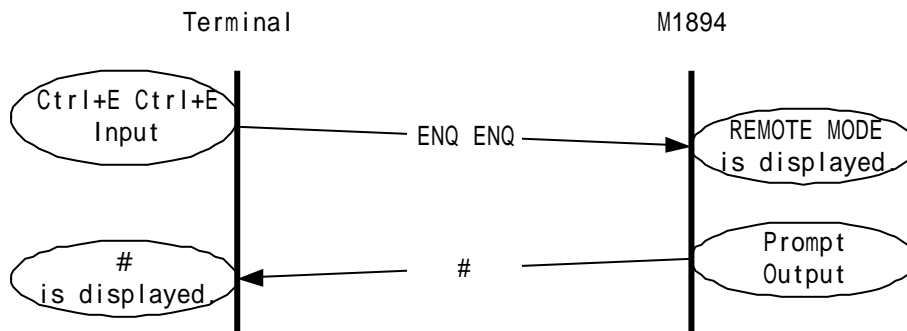

Remarks: In above drawing, PROMOT that is shown as “#” is preset as “#” in the condition of remote mode setting.

PROMPT: “#”	“#” output
PROMPT: “# CR LF”	“# CR LF” output
PROMPT: “none”	no output

## REMOTE COMMAND

Caution of remote operation .....	.85
How to read this chapter .....	.86
Form of remote command .....	.87
Signs to be used in remote command .....	.88
Output form of the results .....	.89
List of commands .....	.90
Explanation of the function .....	.91



# REMOTE COMMAND

## How to read this chapter

	Title	Overview of this section
<b>Explanation of Parameters</b>	<div data-bbox="432 506 1353 573" style="background-color: #cccccc; padding: 2px;"><b>RL - Serial I/F Data Input -</b></div> <p data-bbox="480 595 1382 741">It carries out the data inputting for Serial I/F (RS232C) on the remote mode. At first, M1894 changes Serial I/F into a mode for data input when receiving <b>RL</b> command. Once data is received, the data is converted according to <b>Data Format (S, DF -com)</b> and stored in the buffer memory. A start and end address of the formatted data for inputting and a start address of the buffer memory for storing can be set.</p> <p data-bbox="663 790 799 813">COMMAND:</p> <div data-bbox="687 815 1118 842" style="border: 1px solid black; padding: 2px; display: inline-block;"><b>RL, P1, P2, P3</b></div> <p data-bbox="584 869 703 891">Parameters:</p> <p data-bbox="635 891 1153 913">P1: Formated Data Start Address (Formated Data)</p> <p data-bbox="635 913 1145 936">P2: Formated Data End Address (Formated Data)</p> <p data-bbox="635 936 1118 958">P3: Data Store Start Address (Buffer Memory)</p> <p data-bbox="584 1010 791 1032">Default Values (hex):</p> <p data-bbox="635 1032 719 1055">P1: 00</p> <p data-bbox="635 1055 1102 1077">P2: 1FFFFFFF (with 32M-bytes buffer memory)</p> <p data-bbox="635 1077 719 1099">P3: 00</p> <p data-bbox="504 1160 1382 1182">Remarks: The setting that exceeds the address range of the buffer memory cannot be set.</p> <p data-bbox="504 1211 1382 1279">Caution: Datas cannot be loaded only with <b>RD</b> command input. In addition to that, it is necessary to transmit the formatted data from the external equipment to M1894.</p> <div data-bbox="592 1335 1211 1671" style="border: 1px solid black; padding: 5px; margin: 10px 0;"> <p data-bbox="603 1335 703 1357">Receiving</p> <div data-bbox="603 1361 1211 1420" style="border: 1px solid black; padding: 2px; display: flex; justify-content: space-between;"> <span>RL</span> <span>P1 P1 P1 P1 P1 P1</span> <span>P2 P2 P2 P2 P2 P2</span> <span>P3 P3 P3 P3 P3 P3</span> <span>CR(LF)</span> </div> <div data-bbox="667 1424 1118 1514" style="text-align: center; margin-top: 5px;"> <div style="display: flex; justify-content: space-around; margin-bottom: 5px;"> <span>← P1: →</span> <span>← P2: →</span> <span>← P3: →</span> </div> <div style="display: flex; justify-content: space-around;"> <span>Formated data Start Address</span> <span>Formated data End Address</span> <span>Buffer Start Address</span> </div> </div> <p data-bbox="619 1536 1190 1603" style="text-align: center;">: &lt;&lt; Transfer the formated data from the external equipment &gt;&gt; :</p> <p data-bbox="619 1615 1198 1637" style="text-align: center;">P A S S , R L SP SP SP SP SP SP SP SP SP SP SP SP SP SP SP SP ; CR LF</p> </div>	
<b>Default values of Parameters</b>		
<b>Remarks</b>		
<b>Caution</b>		
	120	Page Number

This shows the output from M1894.

## Form of remote command

### Input Form of The Remote Command

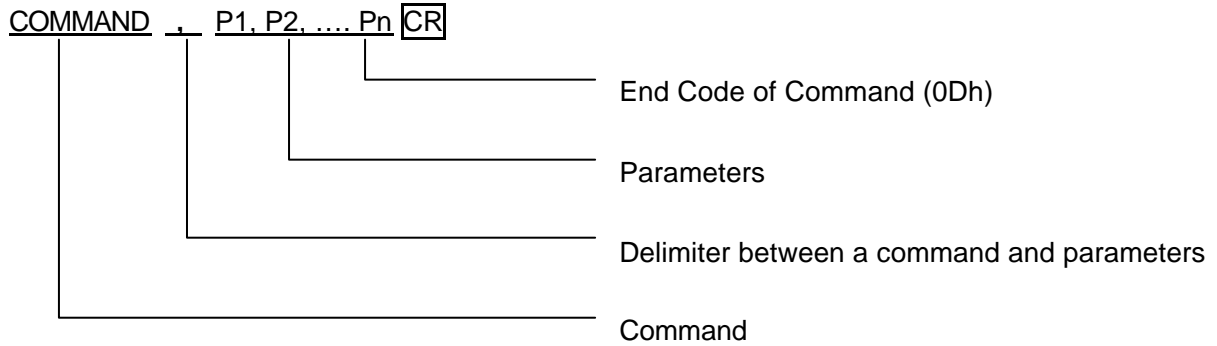

Remarks: All commands should be in capital letter.  
A number of parameter depends on commands

### Elimination of parameter

When changing some parameters and not changing others with command that is needed some parameters, those commands that are not changed can be eliminated.

Basic Form	COMMAND, P1, P2, P3 CR
Elimination in case of changing P1 only	COMMAND, P1 CR
Elimination in case of changing P3 only	COMMAND, , P3 CR

## Signs to be used in remote command

Signs using in this chapter and for command input is defined as follows.

### Definition of signs

[n]	A sign outputting from the external equipment, and no Echo-Back from the programmer.
$\boxed{n}$	A sign outputting from the external equipment, and no Echo-Back from the programmer. (ECHO-Back is settable.)
(n)	A sign outputting from the programmer (It will be outputted when ECHO-Back is ON, but not outputted when OFF.)
$\underline{N}$	A sign outputting from the Programmer
SP	Space
CR	Carriage Return
LF	Line Feed (Skipping)
D1	<b>XON</b>
D3	<b>XOFF</b>

## Output form of the results

Output forms are divided into 2 kinds of command, operation commands and others. And each form is different.

Remarks: Operation commands... They are commands those operate the device electrically, "COPY", "PROG", ...etc.

Others..... They are commands those carry out several settings, "PAE", "Buffer init", ...etc.

### Output forms of the result (Operation commands)

#### PASS END

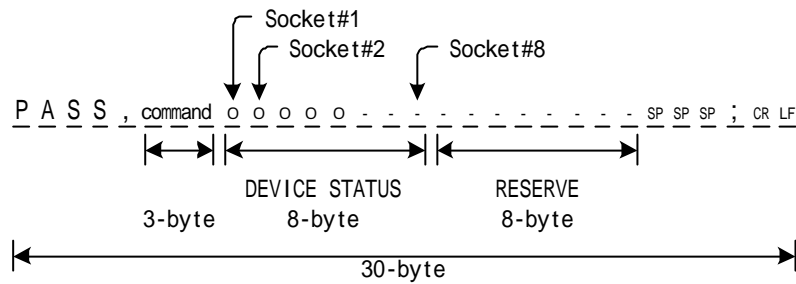

#### FAIL END (Failure end)

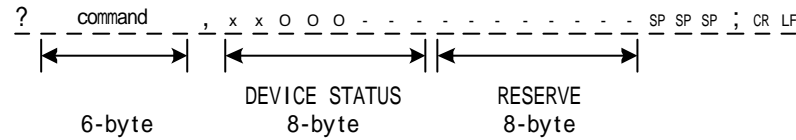

### Output forms of the result (Others)

#### PASS END

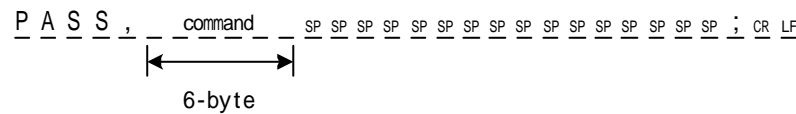

#### FAIL END

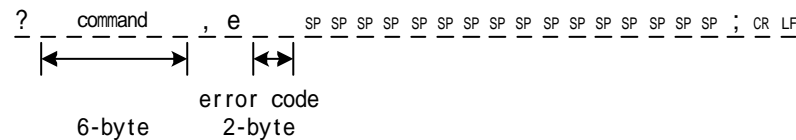

Remarks: SP... Space  
CR...Carriage Return  
LF... Line Feed

## List of commands

### List of commands

Command	Operation	Parameter	Page No.
Ctrl+E Ctrl+E	Starting of Remote Mode		91
E, BY	Ending of Remote Mode		91
RMD	Setting of Remote Mode Condition	P1-P8	92
Ctrl+D	Interruption of Operation		93
H	Display of Help List		94
N, DV	Selecting of Device Code	P1	95
OP, CP	Execution of <b>COPY</b>		96
Z, ER	Execution of <b>ERASE</b>		97
B, BL	Execution of <b>BLANK</b>		98
W, PG	Execution of <b>PROG</b>		99
V, VF	Execution of <b>VERIFY</b>		100
OT, CT	Execution of <b>CONT</b>		101
CK	Contact Checking with a Device		102
SIG	Setting of ID Check	P1	103
MD, PAE	Specification of Operation Range of Device	P1-P3	104
S, DF	Setting of Transfer Data Format	P1	105
BLK	Writing difference datas to devices at the same time	P1	107
BS	Display of Buffer Memory Size		109
REV	Display of Firmware Version		110
L, LS	Display of Buffer Memory Data	P1, P2	111
BO, CS	SUM (4-digits)		112
BO8, CS8	SUM (8-digits)		113
F, INI	Buffer Initialization	P1-P10	114
SCH	Data Searching: correspondance	P1-P10	115
UNS	Data Searching: uncorrespondance	P1-P3	116
T	Transferring of Data	P1-P3	117
P, PL, WD	Serial I/F Data Output	P1, P2	118
RD	Serial I/F Data Input	P1, P2	119
RL	Serial I/F Data Input	P1-P3	120
PCH	Changing of Protect Setting	P1	121
WP	Serial I/F Protected Information Output		122
RP	Serial I/F Protected Information Input	P1, P2	123

Remark: All commands should be in capital letter.

## Ctrl + E Ctrl + E - Starting of Remote Mode -

The Remote Mode Operation Is started.

COMMAND:

**Ctrl+E Ctrl+E**

or

**ENQ(05h) ENQ(05h) code**

Remarks: When **PROMPT** is set “#” or “# **CR LF**”, “#” will be displayed on the display panel.

## E, BY - Ending of Remote Mode -

The Remote Mode Operation is ended.

COMMAND:

**E**

or

**BY**

Parameters: none

## RMD - Setting of Remote Mode Condition -

You can change or check the remote mode setting.

COMMAND:

**RMD, P1, P2, P3, P4, P5, P6, P7**

Parameters:

P1: ECHO Back	0: ON	1: OFF	
P2: PROMPT	0: #	1: # CR LF	2: none
P3: Time Out	0: OFF	1-FF: ---	(0 const.)
P4: ACK/NAK	0: OFF	1: ON	
P5: Command Type	0: ---	1: M1900	(1 const.)
P6: Buzzer	0: ON	1: OFF	
P7: Dummy Read	0: ---	1: ON	(1 const.)

Checking

```

R M D CR (LF)

SP 0 SP SP SP E C H O SP O N SP SP SP SP CR LF
SP 0 SP SP SP # SP SP SP SP SP SP SP SP SP CR LF
SP 0 SP SP SP T M O SP O F F SP SP SP SP CR LF
SP 0 SP SP SP A C K / N A K SP O F F CR LF
SP 1 SP SP SP M 1 9 0 0 SP m o d e SP CR LF
SP 1 SP SP SP B U Z Z E R SP O F F SP CR LF
SP 1 SP SP SP P D M SP O N SP SP SP SP CR LF
P A S S , R M D SP SP SP SP SP SP SP SP SP SP SP SP SP SP SP SP SP SP SP SP SP SP ; CR LF
    
```

Changing

```

R M D , P 1 , P 2 , P 3 P 3 , P 4 , P 5 , P 6 , P 7 CR (LF)

P A S S , R M D SP SP SP SP SP SP SP SP SP SP SP SP SP SP SP SP SP SP SP SP SP SP ; CR LF
    
```

## Ctrl + D - Interruption of Operation -

The processing under present execution is interrupted and it changes into the state of the waiting for a command.

COMMAND:

**Ctrl+D**

or

**BLEAK code**

Parameters: none

## H - Display of Help list -

Display the Remote command list.

COMMAND:

H

Parameters: none

H|CR|(LF)

### Example

```
*****
* M1894 remote command *
*****
*** remote mode control ***
E,BY : remote mode end RMD : remote config.
REV : prom version display H : help message display
BS : buffer size display ^D : cancel command(none)
break : cancel command ^E^E : remote start
*** data in/out command ***
S,DF : transfer format set F,INI : buffer mem initialize
P,PL,WD : serial output RL,RD : serial input
*** UNIT EXECUTE COMMAND ***
OP,CP : copy command OT,CT : cont command
B,BL : blank command V,VF : verify command
W,PG : program command Z,ER : eeprom erase command
CK : contact check command
*** other command ***
BO,CS : check sum calc. N,DV : device select
L,LS : buffer mem display T : buffer mem transfer
SCH : buffer mem search UNS : buffer mem un_search
```

```
P A S S , H SP SP SP SP SP SP SP SP SP SP SP SP SP SP SP SP SP SP SP SP ; CR LF
```

## N, DV - Selecting of Device code -

Select the device code or check the present device code that is selected.

COMMAND:

**N, P1**

OR

**DV, P1**

Parameters: P1 (Device Code) 6-digits

Remarks: Both "N" and "DV" carry out the same operation.

Checking of the device code (Example: Device code = 020101 )

```

N CR (LF)
0 2 0 1 0 1 CR LF
P A S S , N SP SP SP SP SP SP SP SP SP SP SP SP SP SP SP SP SP SP SP SP SP ; CR LF
    
```

Remarks: The result becomes an error when Base unit is not installed. And then, the selection of the device code becomes invalid. (Device code is set to invalid number, 000000.)

Selecting of the device code

```

N , P1 P1 P1 P1 P1 P1 CR (LF)
P A S S , N SP SP SP SP SP SP SP SP SP SP SP SP SP SP SP SP SP SP SP SP SP ; CR LF
    
```

Remarks: The result becomes an error when Base unit is not installed. And then, the selection of the device code becomes invalid. (Device code is set to invalid number, 000000.)

## OP, CP - Execution of COPY -

It carries out **COPY** operation on the remote mode.

COMMAND:

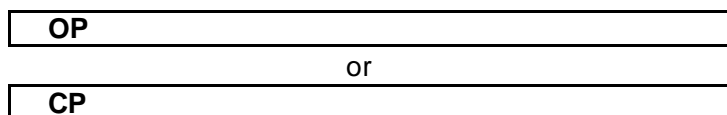

Parameters: none

Remarks: Both “**OP**” and “**CP**” carry out the same operation.

Normally, **COPY** enables to read data from #1 Device-socket only.

In case of “Set Prg mode” is set, copy socket is changed accordingly.

-> **Reference: “Set Prg mode”** (Applicable Operations)

Caution: Make sure to execute “**CK**” command (Contact check with a Device) before “**OP**” and “**CP**” command execution.

-> **Reference: “CK”** (This chapter)

Execution

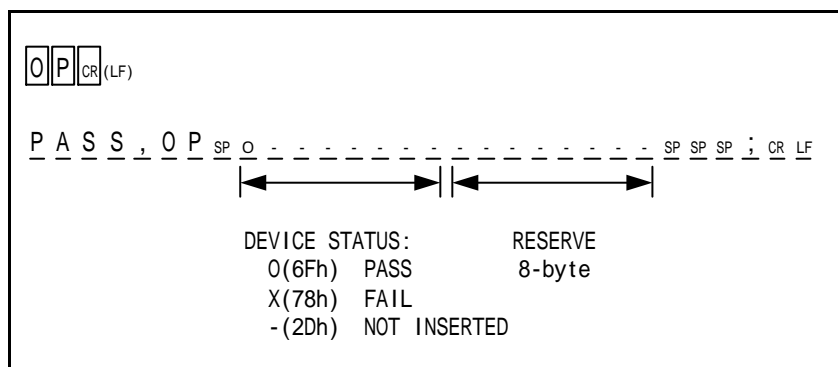

Remarks: The result becomes an error when Base unit is not installed or different types of units are installed.

And then, All of device status becomes ‘-’ (2Dh).

## Z, ER - Execution of ERASE -

It carries out **ERASE** operation on the remote mode.

COMMAND:

<b>Z</b>
OR
<b>ER</b>

Parameters: none

Remarks: Both “**Z**” and “**ER**” carry out the same operation.

It is enabled when electric-erasable device (EE-PROM, FLASH, etc.) is selected.

Caution: Make sure to execute “**CK**” command (Contact check with a Device) before “**Z**” and “**ER**” command execution. -> **Reference: “CK”** (This chapter)

Execution

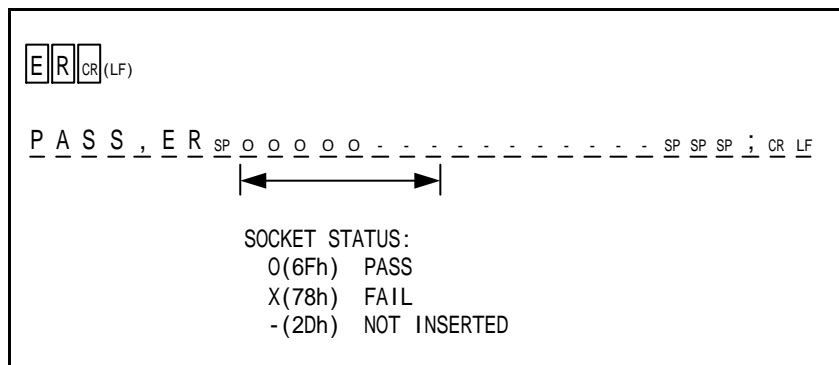

Remarks: The result becomes an error when Base unit is not installed or different types of units are installed.

And then, All of device status becomes '-' (2Dh).

## B, BL - Execution of BLANK -

It carries out **BLANK** operation on the remote mode.

COMMAND:

<b>B</b>
or
<b>BL</b>

Parameters: none

Remarks: Both “**B**” and “**BL**” carry out the same operation.

Caution: Make sure to execute “**CK**” command (Contact check with a Device) before “**B**” and “**BL**” command execution. -> **Reference:** “**CK**” (This chapter)

Execution

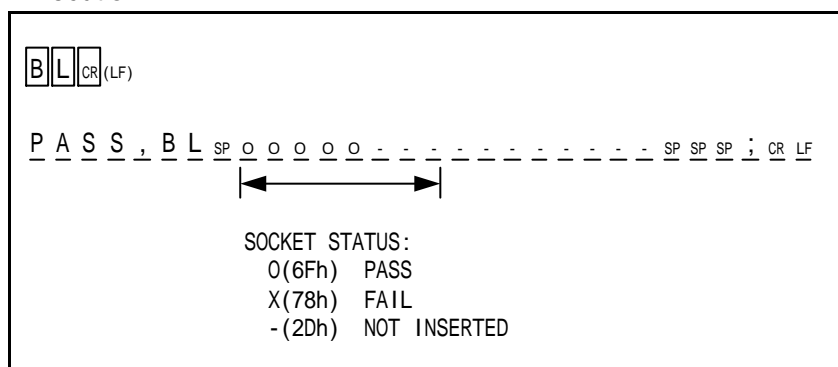

Remarks: The result becomes an error when Base unit is not installed or different types of units are installed.  
 And then, All of device status becomes '-' (2Dh).





## OT, CT - Execution of CONT -

It carries out **CONT** operation on the remote mode.

COMMAND:

<b>OT</b>
or
<b>CT</b>

Parameters: none

Remarks: Both “**OT**” and “**CT**” carry out the same operation.

Caution: Make sure to execute “**CK**” command (Contact check with a Device) before “**OT**” and “**CT**” command execution. -> **Reference: “CK”** (This chapter)

Although the execution is interrupted temporarily and it asks for removing the FAIL device in case of panel operation when **BLANK** operation in **CONT** becomes FAIL at the panel operation. In case of remote mode the operation is not interrupted and it is continued at the remote operation.

That device will be judged as failure.

-> **Reference: “CONT”** (Basic Operation)

Execution

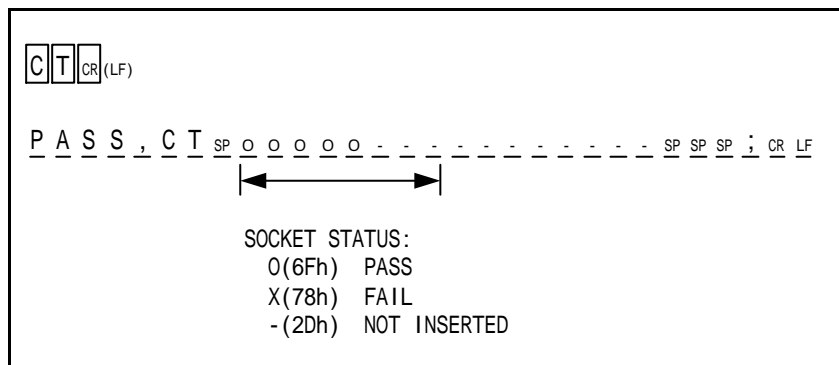

Remarks: The result becomes an error when Base unit is not installed or different types of units are installed.

And then, All of device status becomes '-' (2Dh).

## CK - Contact Checking with a Device -

It carries out the contact checking with devices on the remote mode.

COMMAND:

**CK**

Parameters: none

Caution: Before you execute commands such as “**OP (COPY)**”, “**BL (BLANK)**” on the remote mode, make sure to carry out the contact checking with devices with this command and remove failure devices, then execute each command for operation.

Execution (at PASS End.)

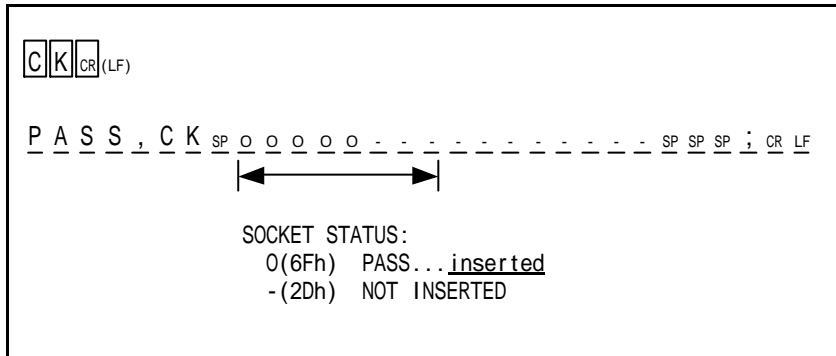

Execution (at FAILURE End.)

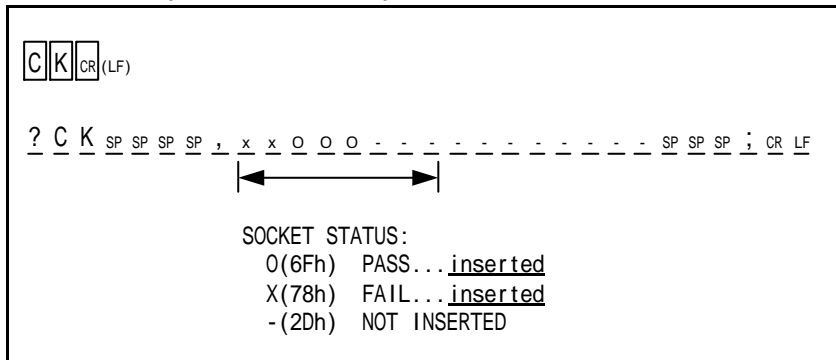

Remarks: The result becomes an error when Base unit is not installed or different types of units are installed.

And then, All of device status becomes '-' (2Dh).



## MD, PAE - Specification of Operating Range of Device -

It sets up or checks **PAE mode** on the remote mode.

COMMAND:

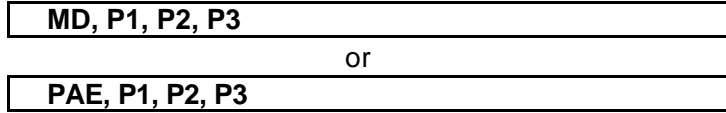

Parameters:

- P1: Operation Start Address (Device)
- P2: Operation End Address (Device)
- P3: Operation Start Address (Buffer Memory)

Remarks: Both “**MD**” and “**PAE**” carry out the same operation.

The setting that exceeds the address of the selected device cannot be set.

The setting that exceeds the address range of the buffer memory cannot be set.

-> **Reference: “PAE mode”** (Applicable Operations)

Checking

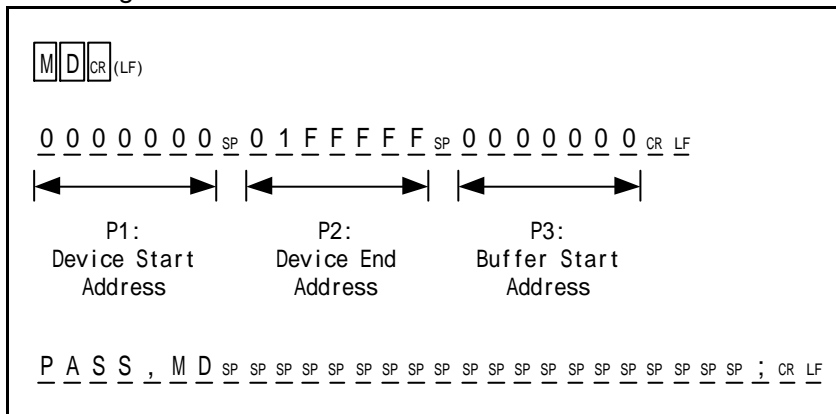

Setting

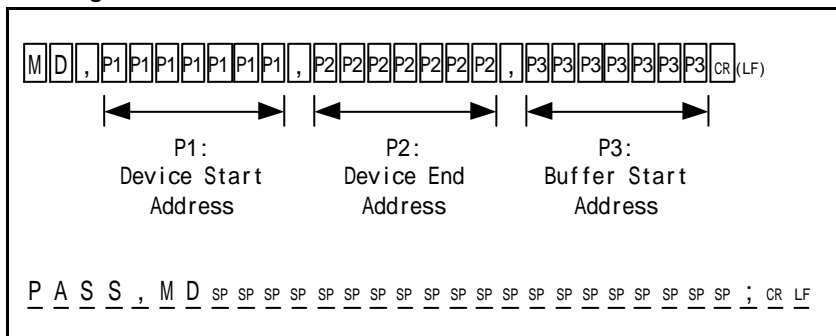

## S, DF - Setting of Transfer Data Format -

It sets up or checks **Data Format** on the remote mode.

COMMAND:

<b>S, P1</b>
or
<b>DF, P1</b>

Parameters: P1 Data Format Number 2-digits

Remarks: Both “**S**” and “**DF**” carry out the same operation.

-> **Reference: “Data Format” (Memory)**

Format List

P1 (hex)	Data Format
00:	MINATO HEX
01:	-----
02:	INTEL HEX
03:	HP64000 ABS
04:	-----
05:	MOTOROLA S
06:	-----
07:	-----
08:	-----
09:	-----
10:	-----
11:	-----
12:	-----
13:	-----
14:	No Format
Others	-----

Remarks: “-----” means an error.

### Checking

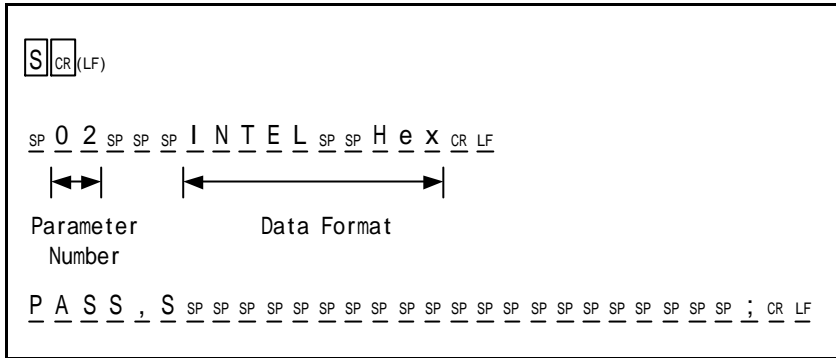

### Setting

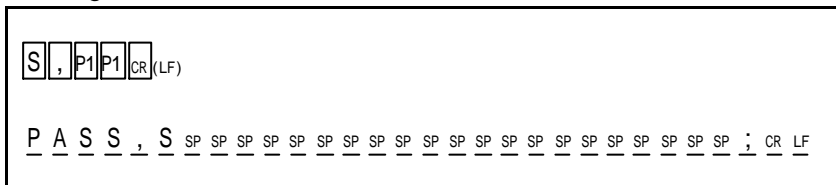

## BLK - Writing difference datas to devices at the same time -

It sets up or checks **Set Prg mode** on the remote mode.

COMMAND:

**BLK, P1**

Parameters: P1 Mode Number 2-digits

Remarks: A default mode when 8-bits device is selected will be "01".

A default mode when 16-bits device is selected will be "11".

When changing a device code setting or turning power on/off, the setting will be set as default.

Mode List

Mode Number	Set mode (Data Width x Blocks)	Data Width of The Selected Device
00	-----	8-bit
01	8bit x1	
02	8bit x2	
03	8bit x4	
04	8bit x8	
05	16bit x1	
06	16bit x2	
07	16bit x4	
08	32bit x1	
09	32bit x2	
0A	-----	16-bit
0B	-----	
10	-----	
11	16bit x1N	
12	16bit x2N	
13	16bit x4N	
14	16bit x8N	
15	32bit x1N	
16	32bit x2N	
17	32bit x4N	
18	-----	-----
Others	-----	

Remarks: "-----" means an error.

### Checking

```
B L K CR(LF)
B L O C K _ M O D E SP 0 1 : SP SP 8 B I T x 1 SP SP CR LF
      |<>|
      Parameter
      Number
P A S S , B L K SP SP SP SP SP SP SP SP SP SP SP SP SP SP SP SP SP SP SP SP ; CR LF
```

### Setting

```
B L K , P1 P1 CR(LF)
P A S S , B L K SP SP SP SP SP SP SP SP SP SP SP SP SP SP SP SP SP SP SP SP ; CR LF
```



## REV - Display of Firmwere Version -

A firmware version for M1894 is outputted to the external equipment.

COMMAND:

REV

Parameters: none

Execution

R E V CR(LF)

SP V SP 1 . 0 0 SP SP SP SP SP SP SP SP SP CR LF

P A S S , R E V SP SP SP SP SP SP SP SP SP SP SP SP SP SP SP SP ; CR LF

## L, LS - Display of Buffer Memory Data -

Buffer memory data is outputted to the external equipment. An output address range can be selected.

COMMAND:

**L, P1, P2**  
 or  
**LS, P1, P2**

Parameters:

P1: Output Start Address (Buffer Memory)

P2: Output End Address (Buffer Memory)

Remarks: Both "L" and "LS" carry out the same operation.

The setting that exceeds the address range of the buffer memory cannot be selected.

Example (Outputting data that is initialized with '03,06,0C,...')

Operating range: 0-FFh

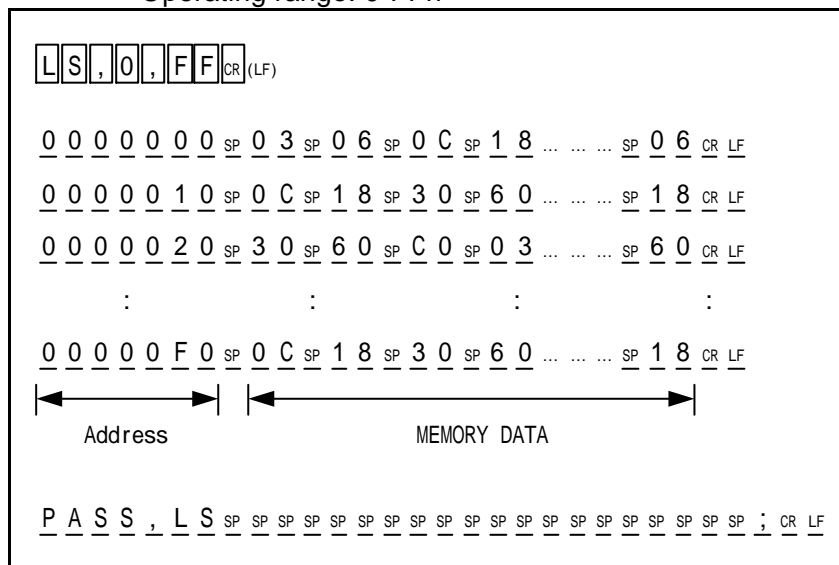

## BO, CS - SUM (4-digits) -

The data sum in the buffer memory that is calculated with the address range of present setting (**PAE**) is outputted to the external equipment in 4-digits.

COMMAND:

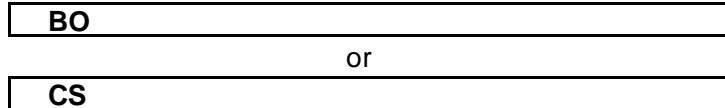

Parameters: none

Caution: In general, **PAE mode** is enabled, but that is disabled during **Set Prg mode**.

Remarks: Both “**BO**” and “**CS**” carry out the same operation.

Output

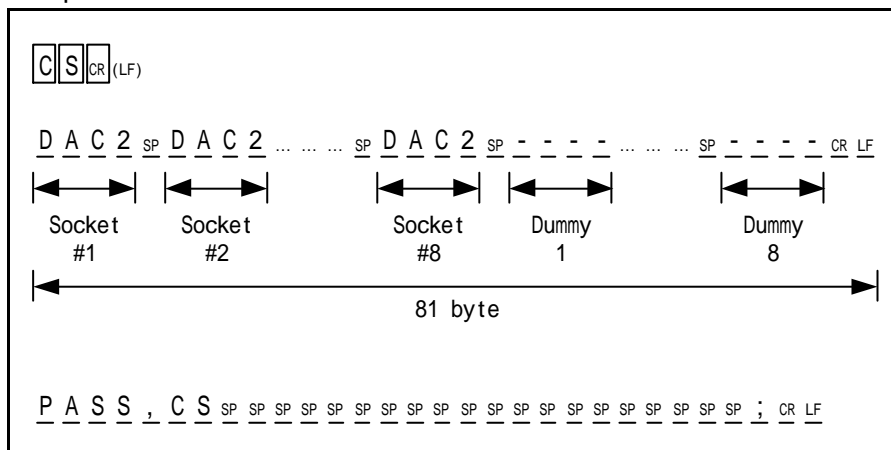

Remarks: Sums are outputted every each socket. And dummy datas “-” for additional 8 sockets will be outputted continually after sums as sockets #1-#8 is outputted. This is for a compatibility with our other programmers.

## BO 8, CS 8 - SUM (8-digits) -

The data sum in the buffer memory that is calculated with the address range of present setting (**PAE**) is outputted to the external equipment in 8-digits.

COMMAND:

**BO 8**

OR

**CS 8**

Parameters: none

**Caution:** This command is not valid for “Set Prg mode” (BLK command), as the command carries out calculating the data sum of buffer memory with address range of only #1 device socket.

**Please use commands “BO” or “CS” when this mode is setted up. PAE setting is enabled.**

Remarks: Both “**BO8**” and “**CS8**” carry out the same operation.

Example

**C S 8** CR (LF)

3 6 6 D B 6 A 8 CR LF

P A S S , C S 8 SP SP SP SP SP SP SP SP SP SP SP SP SP SP SP SP SP SP ; CR LF

## F, INI - Buffer Initialization -

It initializes the buffer memory. You can set a certain initializing data in repeatable pattern with maximum 8-bytes. An address range of the buffer memory can be set.

COMMAND:

**F, P1, P2, P3, P4, P5, P6, P7, P8, P9, P10**

or

**INI, P1, P2, P3, P4, P5, P6, P7, P8, P9, P10**

Parameters:

P1: Initialize Start Address (Buffer Memory)

P2: Initialize End Address (Buffer Memory)

P1- 10: Initialize Data

Default Values (hex):

P1: 00

P2: 1FFFFFFF (with 32M-bytes buffer memory)

P3-10: FF

Remarks: Both "F" and "INI" carry out the same operation.

The setting that exceeds the address range of the buffer memory cannot be set.

Setting

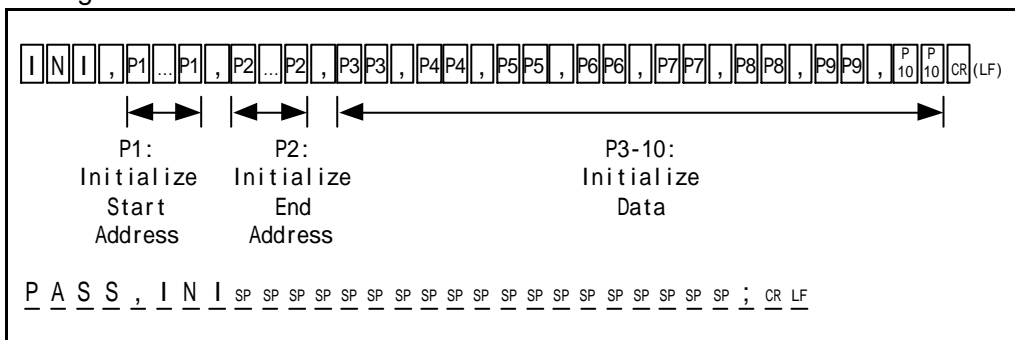

Example1 ) Initialize all buffer memory data with "FF"

**COMMAND:** INI, , , FF **CR**

Example2 ) Initialize all buffer memory data with "03, 06, ..."pattern.

**COMMAND:** INI, , , 03, 06, 0C, 18, 30, 60, C0 **CR**

## SCH - Data Searching: correspondance -

After seaching a certain line of data (max 8-byte) in the buffer, the result is output.  
 Buffer start address, end address, data line can be set.  
 When the targeted data line is found in the buffer, the address is displayed.  
 When no match is found, the very next of the end address is displayed.

COMMAND:

**SCH, P1, P2, P3, P4, P5, P6, P7, P8, P9, P10**

Parameters:

P1: Search Start Address (Buffer Memory)

P2: Serach End Address (Buffer Memory)

P3-10: Search Data

Default Values (hex):

P1: 00

P2: 1FFFFFF (with 32M-bytes buffer memory)

P3-10: FF

Remarks: The setting that exceeds the address range of the buffer memory cannot be set.

Searching

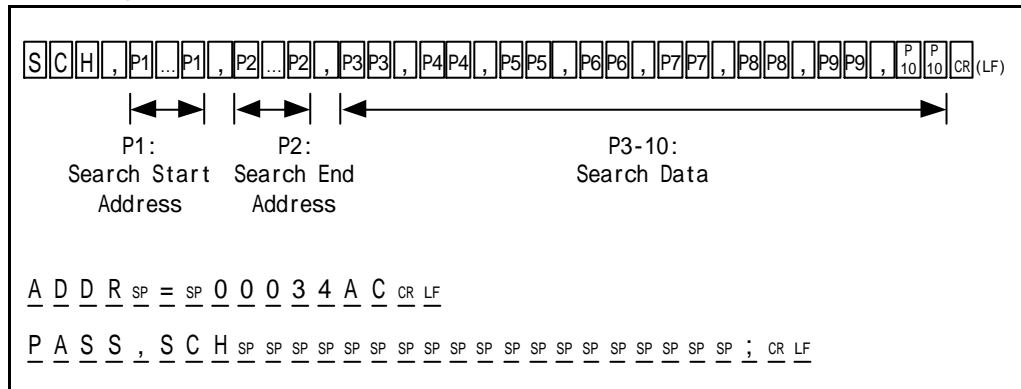

## UNS - Data Searching: uncorrespondance -

Certain data (maximum 1-byte) on the buffer memory is checked by un-correspondant search and the result is output. A start and end address of the buffer memory and a data for searching can be set. When there is a un-correspondant data on the buffer memory, the un-correspondant address will be displayed on the display panel. The next of the end address for searching will be displayed when no match is found.

COMMAND:

**UNS, P1, P2, P3**

Parameters:

- P1: Search Start Address (Buffer Memory)
- P2: Serach End Address (Buffer Memory)
- P3: Search Data (1-byte)

Default Values (hex):

- P1: 00
- P2: 1FFFFFF (with 32M-bytes buffer memory)
- P3: FF

Remarks: The setting that exceeds the address range of the buffer memory cannot be set.

Searching

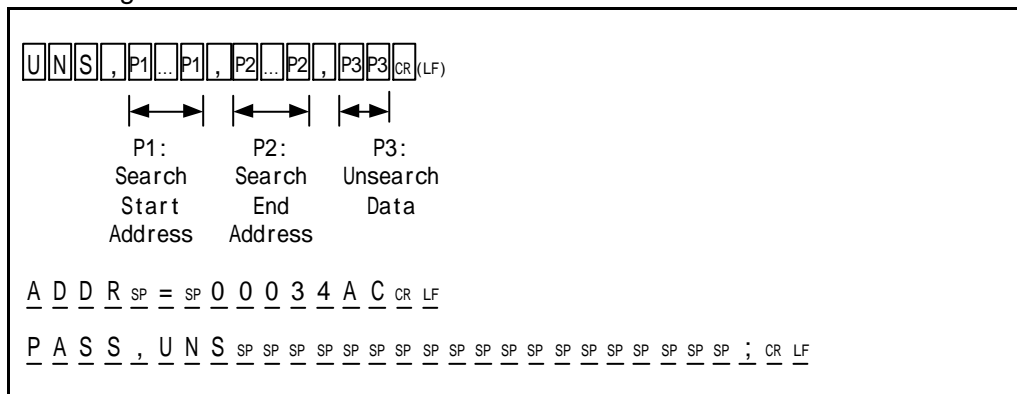

## T - Tranfering of Data -

It copies datas of certain address range of the buffer memory and transfers it to other address space.  
A start and end address for coping and the destination address of the buffer memory can be set.

COMMAND:

**T, P1, P2, P3**

Parameters:

- P1: Copy Start Address (Buffer Memory)
- P2: Copy End Address (Buffer Memory)
- P3: Destination Address (Buffer Memory)

Default Values (hex):

- P1: 00
- P2: 00
- P3: 00

Remarks: The setting that exceeds the address range of the buffer memory cannot be set.

Execution

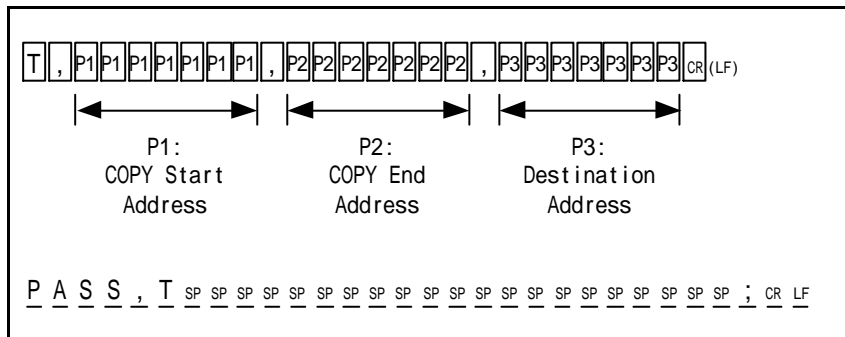

Remarks: The setting that exceeds the address range of the buffer memory cannot be set.

M1894 buffer memory

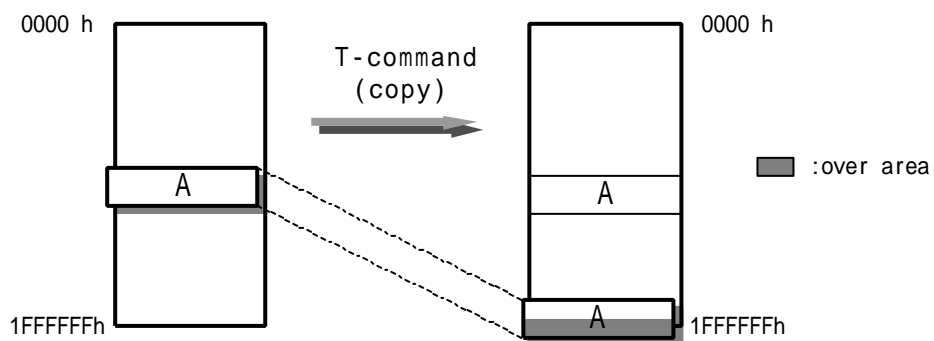

## P, PL, WD - Serial I/F Data Output -

It carries out the data outputting for Serial I/F (RS232C) on the remote mode.

After transforming datas of the buffer memory according to **Data Format (S or DF commands)**, the formatted data will be outputted.

A start and end address of the buffer memory can be set.

COMMAND:

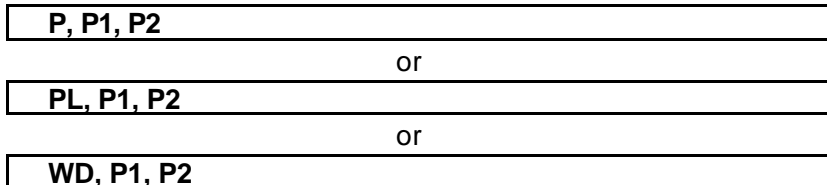

Parameters:

P1: Transmission Start Address (Buffer Memory)

P2: Transmission End Address (Buffer Memory)

Default Values (hex):

P1: 00

P2: 1FFFFFF (with 32M-bytes buffer memory)

Remarks: The setting that exceeds the address range of the buffer memory cannot be set.

Both "P", "PL" and "WD" carry out the same operation.

Example (Output datas of the buffer memory initialized with "03, 06, 0C, ...".

Address range: 00-0Fh, Format: "INTEL hex"

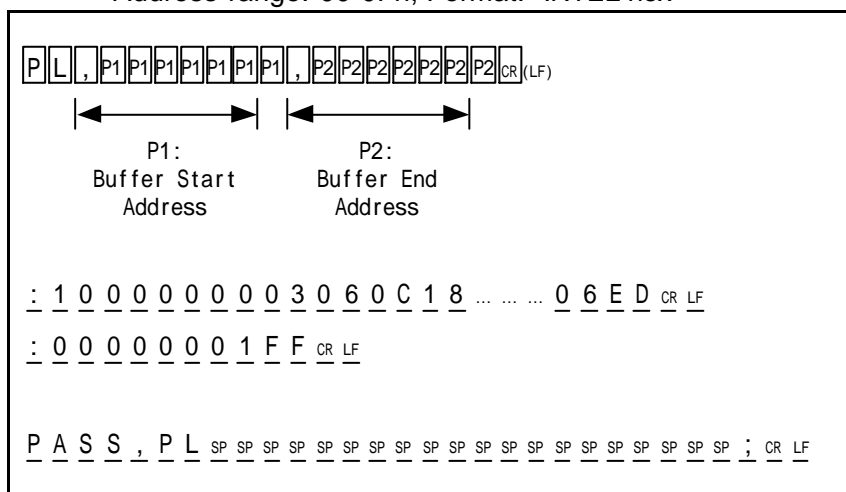

## RD - Serial I/F Data Input -

It carries out the data inputting for Serial I/F (RS232C) on the remote mode.

At first, M1894 changes Serial I/F into a state of the waiting for a formatted data inputting when receiving **RD** command, and then datas will be stored in the buffer memory according to the setting of **Data Format** (**S** or **DF** commands).

A start and end address of the formatted data for inputting can be set.

COMMAND:

**RD, P1, P2**

Parameters:

P1: Formated Data Start Address (Formated Data)

P2: Data Store Start Address (Buffer Memory)

Default Values (hex):

P1: 00

P2: 00

Remarks: The setting that exceeds the address range of the buffer memory cannot be set.

Caution: Datas cannot be loaded only with **RD** command input. In addition to that, it is necessary to transmit the formatted data from the external equipment to M1894.

Receiving

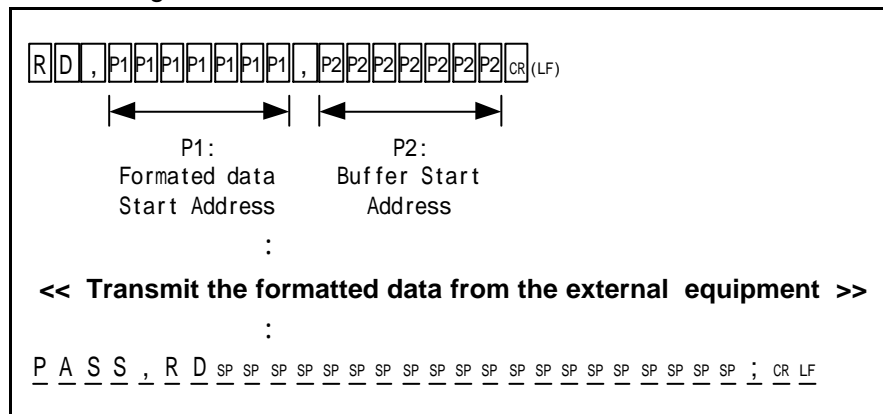

## RL - Serial I/F Data Input -

It carries out the data inputting for Serial I/F (RS232C) on the remote mode.

At first, M1894 changes Serial I/F into a mode for data input. When receiving **RL** command. Once data is received, the data is converted according to **Data Format (S, DF -com)** and stored in the buffer memory.

A start and end address of the formatted data for inputting and a start address of the buffer memory for storing can be set.

COMMAND:

**RL, P1, P2, P3**

Parameters:

P1: Formated Data Start Address (Formated Data)

P2: Formated Data End Address (Formated Data)

P3: Data Store Start Address (Buffer Memory)

Default Values (hex):

P1: 00

P2: 1FFFFFFF (with 32M-bytes buffer memory)

P3: 00

Remarks: The setting that exceeds the address range of the buffer memory cannot be set.

Caution: Datas cannot be loaded only with **RD** command input. In addition to that, it is necessary to transmit the formatted data from the external equipment to M1894.

Receiving

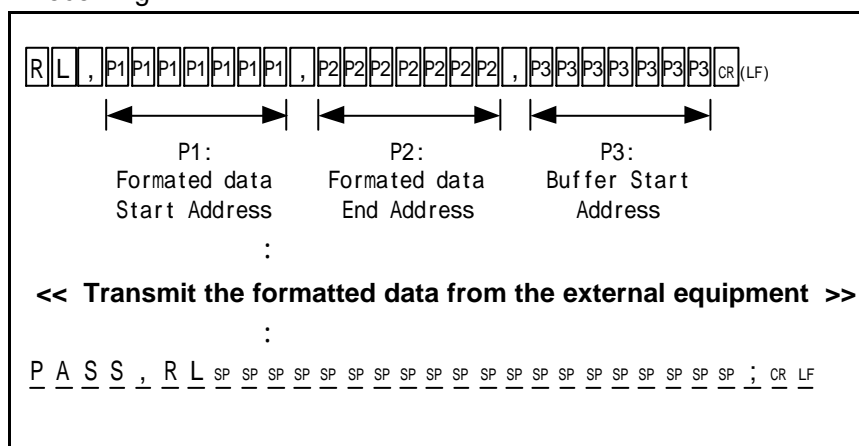

## PCH - Changing of Protect Setting -

It sets or checks **Protect Setting** on the remote mode.

COMMAND:

**PCH, P1**

Parameters: P1 Protect Mode Number

Remarks: When changing a device code setting or turning power on/off, the setting will be set as default.

Mode List

P1 (hex)	Protect Mode
0:	No Operation
1:	Unprotect / Protect
2:	Protect Only

Checking

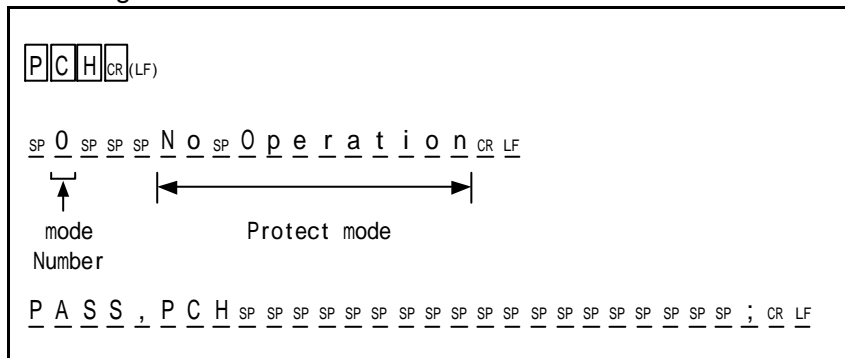

Setting

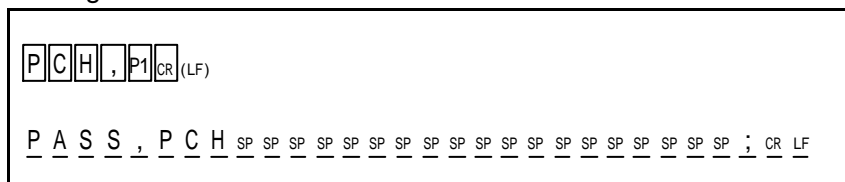

## WP - Serial I/F Protected Information Output -

It carries out the data outputting of the protected information for Serial I/F (RS232C) on the remote mode. After transforming datas of the protected information according to the setting of **Data Format (S or DF commands)**, the formatted data will be outputted to the external equipment.

COMMAND:

**WP**

Parameters: none

Remarks: Each information of hte protection or unprotection will be shown, "01", "00".

Example No.0-1:Protection, others:Unprotection (of 7 areas)

Data Format: INTEL\_FORMAT

```

WP CR(LF)
: 0 7 0 0 0 0 0 0 0 1 0 1 0 0 0 0 0 0 0 0 0 0 F 7 CR LF
   Protect area: [0] [1] [2] [3] [4] [5] [6]
: 0 0 0 0 0 0 0 1 F F CR LF
P A S S , W P SP SP SP SP SP SP SP SP SP SP SP SP SP SP SP SP SP SP SP SP SP ; CR LF
    
```

## RP - Serial I/F Protected Information Input -

It carries out the data inputting of the protected information through Serial I/F (RS232C) on the remote mode. At first, M1894 changes Serial I/F into a mode for a formatted data input when receiving **RP** command. Once data is received, the data is converted according to **Data Format (S or DF)** commands and stored.

A start and end address of the formatted data for inputting can be set.

COMMAND:

**RP, P1, P2**

Parameters:

P1: Formated Data Start Address (Formated Data)

P2: Formated Data End Address (Formated Data)

Default Values (hex):

P1: 00

P2: (The value depending on the selected device will be set.)

Remarks: When changing a device code setting or turning power on/off, the setting will be set as default.

Caution: Data cannot be loaded only with **RP** command input. In addition to that, it is necessary to transmit the formatted data from the external equipment to M1894.

Receiving

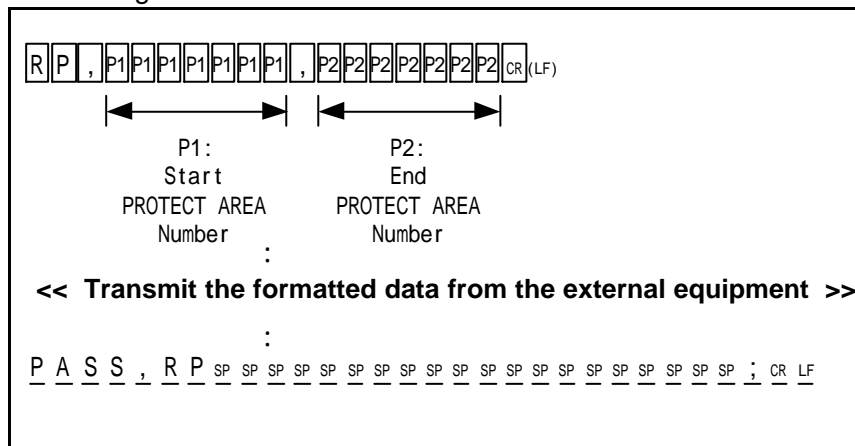

# MAINTENANCE

- Error message** .....125
  - Error message during self-test .....125
  - Error message during operation .....126
  - Error message during remote mode .....126
- After service .....127
- User maintenance of device programmers and adapters .....127
- Specification** .....128
  - Specification of M1894 .....128
  - Specification of connector (RS232C) .....129
  - Specification of connector (USB) .....130
- Head quarter .....131

## Maintenance

### ERROR MESSAGE

#### Error message during self-test

Error indication	Corrective actions
“FPGA Config Error !!”	
“ FPGA Func Error !! ”	
“ FPGA SUM/XOR Error ”	
“ SELF CHECK ERROR !!” [xxxxx]	
“!! Vcc SW Error !! “	Check the device socket.
“!! Vpp SW Error !! “	Check the device socket.
“!! Vhh SW Error !! “	Check the device socket.
“DATA_Read Error X.Xv”	Check the device socket.
“ Verify Error X.Xv”	Check the device socket.
“ PRG_Very Error X.Xv”	Check the device socket.
“ SET_Very Error X.Xv”	Check the device socket.
“Pull up/down Error “	Check the device socket.
“Memory check Error !”	
In case irregular operation occurs	
(No buzzer sounds.)	
(Nothing is indicated on the display.)	
(No LED is lighted.)	

When any of the above error occurred, make sure that no foreign item (including socket adapter) is placed on the device Sockets.

Press the RESET key to execute the self-check again from the beginning.

When error still occurs, please contact to Minato authorized distributor.

### Error message during operation

Error indication	Error overview	Corrective actions
"Empty socket"	There is any device socket in which a device has not been set. Red LED is lit on the corresponding socket.	Check the device-sockets.
"!! OVER CURRENT !!"	Too much current is applied to the device lcc. Red LED is lit on the corresponding socket.	Remove failure devices.

### Error message during remote mode

Error code	Error	Error overview
90	Check Sum Error	Error during Formated Data Transfer
91	Format Error	Error during Formated Data Transfer
F0	Illegal Command	Error when the illegal command is inputed
F1	Parameter Error	Parameter mismatch
F2	Invalid Function	Error when the invalid function is exected (Such as executing ERASE with EPROM device)

## After service

The warranty period of this unit is for one year after the shipment from Minato. Even during the warranty period, we exclude damages as a result of natural disaster, misoperation, modification or change of the unit by user and wear of the device socket from the warranty. Also, please note that we are not obliged to refund for a damaged P-ROM when this unit gets out of order.

In case of anything unclear to you, please contact Minato authorized distributor that you purchase the unit.

## User maintenance of device programmers and adapters

1. Do not keep programmer in dusty and/or humid area. That may cause a damage on the unit. When adapters are used in humid area, that may cause to transfer remaining chemicals from the pins of devices to the contact of the socket adapters. Please be aware that chemical reaction and susts may shorten the life of the adapters.
2. The adapters and Textools are consumable items. When the rate of programming failure is increased that could be a time for you to replace them. Please consult with your local Minato distributor for detail.
3. To clean sockets, please use only air to blow dusts on the sockets. Do not use a contact cleaner that may gather dusts on the contact of the socket adapters.

## Specification

### Specification of M1894

#### Operating Temperature

5-35 ( )

#### Power Supply

100-240VAC (50 / 60 Hz)  
0.9 A at 100VAC, Ta=25 (max.)

#### Dimensions

Width 380 (mm)  
Depth 297 (mm)  
Height 107 (mm)

#### Weight

4.7 (kg)  
(5.2) (kg) Base-unit Mounted

#### Display

Liquid crystal display panel of 20 characters x 4 lines  
2-color LED lamp Suitable to each socket

#### Buffer memory

256 Mbits (Standard)  
1 Gbits (Maximum)

#### External Interface (Serial Interface)

: RS232C  
: USB

#### Others

Device sockets 8

## Specification of connector - RS232C -

Pin Arrangement

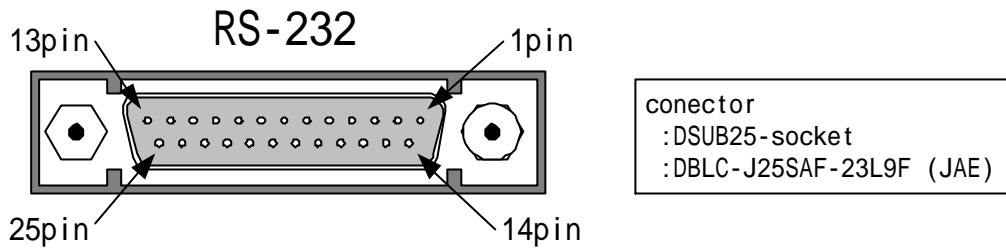

Pin Arrangement List (DCE )

Pin No.	Signal name	Direction	Explanation of Function
1	FG	-	Frame GND
2	TXD	Ex-equipment -> M1894	
3	RXD	Ex-equipment <- M1894	
4	RTS	Ex-equipment -> M1894	
5	CTS	Ex-equipment <- M1894	
6	DSR	Ex-equipment <- M1894	
7	SG	-	Signal GND
8	CD	Ex-equipment <- M1894	
20	DTR	Ex-equipment -> M1894	
22	RI	Ex-equipment <- M1894	

Example of Connection (M1894 ~ PC/AT )

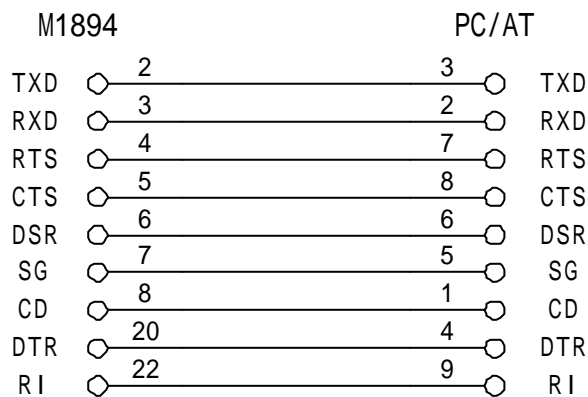

## Pin Arrangement

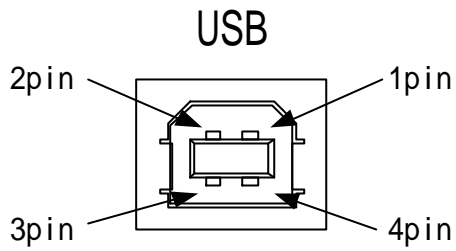

conector  
 :USB-socket (Type\_B)  
 :XM7B-0442 (OMRON)

## Pin Arrangement List (DCE )

Pin No.	Signal name	Explanation of Function
1	VBUS	Power Supply
2	D-	Data
3	D+	Data
4	GND	Signal GND

Warning: One set of PC can be connected to M1894.  
 USB 1.1 standard cable is recommended.

## ***MINATO ELECTRONICS INC.***

JAPAN

MINATO ELECTRONICS Inc.

4105 Minami Yamada-Cho Tsuzuki-Ku,

Yokohama-Shi 224-0026 JAPAN

Tel: (81) 45-592-5549

Fax: (81) 45-592-2854

Web: [www.minato.co.jp](http://www.minato.co.jp)